

# IDEAL INSTITUTE OF TECHNOLOGY

## Department of Electrical Engineering

### TEACHING PLAN

**Subject:** Fundamental of Electrical Machines and Measurement (FEMM)

**Subject Code:** EEC303

**Name of Faculty:** Mr. Rambhavan Pal

**Semester/Year - III/II**

**Academic Year:** 2023-24

EC NO	DATE	TOPIC PLANNED	DATE	TOPIC ACTUALLY COVERED	REAMRKS
1	18/07/23	Basics of Magnetism: Magnetic field and circuit,	18/07/23	Basics of Magnetism: Magnetic field and circuit,	
2	19/07/23	Magnetic field and circuit,	19/07/23	Magnetic field and circuit,	
3	20/07/23	Numerical based on series parallel magnetic circuit,	20/07/23	Numerical based on series parallel magnetic circuit,	
4	21/07/23	Numerical based on series parallel magnetic circuit,	21/07/23	Numerical based on series parallel magnetic circuit,	
5	25/07/23	Flux linkage, Inductance and energy,	25/07/23	Flux linkage, Inductance and energy,	
6	26/07/23	Flux linkage, Inductance and energy,	26/07/23	Flux linkage, Inductance and energy,	
7	27/07/23	Faraday's laws,	27/07/23	Faraday's laws,	
8	28/07/23	Hysteresis and eddy current losses.	28/07/23	Hysteresis and eddy current losses.	
9	01/08/23	Hysteresis and eddy current losses.	01/08/23	Hysteresis and eddy current losses.	
10	02/08/23	Numerical on series parallel magnetic circuit,	02/08/23	Numerical on series parallel magnetic circuit,	

11	03/08/23	Numerical on series parallel magnetic circuit	03/08/23	Numerical on series parallel magnetic circuit	
12	04/08/23	Numerical on series parallel magnetic circuit	04/08/23	Numerical on series parallel magnetic circuit	
13	08/08/23	Electromechanical Energy Conversion: Principle, Energy stored in	08/08/23	Electromechanical Energy Conversion: Principle, Energy stored in	
14	09/08/23	Energy stored in	09/08/23	Energy stored in	
15	10/08/23	Principle, Energy stored in magnetic field,	10/08/23	Principle, Energy stored in magnetic field,	
16	11/08/23	Field and co energy, Force and torque equations, Torque in singly and doubly excited systems,	11/08/23	Field and co energy, Force and torque equations, Torque in singly and doubly excited systems,	
17	16/08/23	Magnetic field in rotating machines, Rotating MMF wave Leakage flux and magnetic saturation.	16/08/23	Magnetic field in rotating machines, Rotating MMF wave Leakage flux and magnetic saturation.	
18	17/08/23	Magnetic field in rotating machines, Rotating MMF wave Leakage flux and magnetic saturation.	17/08/23	Magnetic field in rotating machines, Rotating MMF wave Leakage flux and magnetic saturation.	
19	18/08/23	Magnetic field in rotating machines, Rotating MMF wave Leakage flux and magnetic saturation.	18/08/23	Magnetic field in rotating machines, Rotating MMF wave Leakage flux and magnetic saturation.	
20	22/08/23	DC Machines: Review of construction and components of DC machine;	22/08/23	DC Machines: Review of construction and components of DC machine;	
21	23/08/23	Characteristics of DC generators and motors (speed – torque and performance);	23/08/23	Characteristics of DC generators and motors (speed – torque and performance);	
22	24/08/23	Characteristics of DC generators and motors (speed – torque and performance);	24/08/23	Characteristics of DC generators and motors	

				(speed – torque and performance);	
23	25/08/23	Braking methods, Losses and efficiency,	25/08/23	Braking methods, Losses and efficiency,	
24	29/08/23	Braking methods, Losses and efficiency,	29/08/23	Braking methods, Losses and efficiency,	
25	30/08/23	Swinburne’s, Hopkinson’s	30/08/23	Swinburne’s, Hopkinson’s	
26	31/08/23	Swinburne’s, Hopkinson’s	31/08/23	Swinburne’s, Hopkinson’s	
27	05/09/23	Retardation tests;	05/09/23	Retardation tests;	
28	06/09/23	Potentiometers, Bridges and Transducers: Potentiometers: Basic potentiometer circuit;	06/09/23	Potentiometers, Bridges and Transducers: Potentiometers: Basic potentiometer circuit;	
29	07/09/23	Bridges: Wheatstone, Kelvin’s double bridge,	07/09/23	Bridges: Wheatstone, Kelvin’s double bridge,	
30	08/09/23	Maxwell’s bridge, Schering Bridge,	08/09/23	Maxwell’s bridge, Schering Bridge,	
31	12/09/23	Q meter. Transducers:	12/09/23	Q meter. Transducers:	
32	13/09/23	Classification of transducers,	13/09/23	Classification of transducers,	
33	14/09/23	Hall effect, Optical and digital transducers.	14/09/23	Hall effect, Optical and digital transducers.	
34	15/09/23	Basic requirements of signal conditioning circuits. Amplifier, Filter, and linearization circuit.	15/09/23	Basic requirements of signal conditioning circuits. Amplifier, Filter, and linearization circuit.	
35	19/09/23	Digital Measurements: Advantages of digital meters over analog meters,	19/09/23	Digital Measurements: Advantages of digital meters over analog meters,	

36	20/09/23	Resolution & sensitivity of digital meters, Working principles of digital Voltmeter and Ammeter,	20/09/23	Resolution & sensitivity of digital meters, Working principles of digital Voltmeter and Ammeter,	
37	21/09/23	Resolution & sensitivity of digital meters, Working principles of digital Voltmeter and Ammeter,	21/09/23	Resolution & sensitivity of digital meters, Working principles of digital Voltmeter and Ammeter,	
38	22/09/23	Working principles and features of Digital Tachometer and Digital Megger	22/09/23	Working principles and features of Digital Tachometer and Digital Megger	
39	26/09/23	Multi-meter; Digital Storage Oscilloscope; Introduction to MEMS (micro-electromechanical systems) technology	26/09/23	Multi-meter; Digital Storage Oscilloscope; Introduction to MEMS (micro-electromechanical systems) technology	
40	27/09/23	their applications in electrical and automotive domain.	27/09/23	their applications in electrical and automotive domain.	

Semester-III								
Course Code	Course Name	Teaching Scheme (Contact Hours)			Credits Assigned			
		Theory	Pract.	Tut.	Theory	TW/Pract.	Tut.	Total
EEC303	<b>Fundamentals of Electrical Machines &amp; Measurements</b>	04	-	-	04	-	-	04

Examination Scheme								
Theory					Term Work/Practical/Oral			Total
Internal Assessment			End Sem Exam	Duration of End Sem. Exam	Term Work	Pract.	Oral	
Test-I	Test-II	Average						
20	20	20	80	03 Hrs	-	-	-	100

<b>Course Objectives</b>	<p><b>The course is aimed:</b></p> <ol style="list-style-type: none"> <li>To study the concepts of magnetism and energy conversion.</li> <li>To familiarize with the operational characteristics of DC machines and their applications.</li> <li>To learn the working principles of various analog and digital instruments &amp; devices used for measurement of the various electrical and electronic parameters.</li> </ol>
<b>Course Outcomes</b>	<p><b>Upon successful completion of this course, the learner will be able to:</b></p> <ol style="list-style-type: none"> <li>Illustrate the principle of energy conversion in single and double excited machines.</li> <li>Understand and analyze the significance of the DC machines performance parameters.</li> <li>Implement various starting methods and speed control methods for DC machines applications</li> <li>Evaluate the working of various sensors, transducers and analog / digital instruments used in electrical and electronic measurements.</li> <li>Analyze the use and performance of bridges used in electrical and electronic measurements.</li> <li>Illustrate the need for extension of range of meters and calibration in instruments.</li> </ol>

Module	Detailed Contents	Hours
1	<p><b>Basics of Magnetism:</b> Magnetic field and circuit, Numerical based on series parallel magnetic circuit, Flux linkage, Inductance and energy, Faraday's laws, Hysteresis and eddy current losses.</p>	05
2	<p><b>Electromechanical Energy Conversion:</b> Principle, Energy stored in magnetic field, Field and co energy, Force and torque equations, Torque in singly and doubly excited systems, MMF in distributed windings Winding inductance, Magnetic field in rotating machines, Rotating MMF wave Leakage flux and magnetic saturation.</p>	09
3	<p><b>DC Machines:</b> Review of construction and components of DC machine, commutator and brushes, concept of back EMF, and torque equations, Types of DC machines; Armature reaction, Characteristics of DC generators and motors (speed – torque and performance), Necessity of starter and types, Speed control and braking methods, Losses and efficiency, Swinburne's, Hopkinson's and Retardation tests; PMDC motor.</p>	12

4	<p><b>Analog Measurement:</b> Fundamental element of an instrument, Static and dynamic characteristics, Errors in Measurement, Standards and calibrations, Difference between indicating and integrating instruments, Moving coil and moving iron instruments, Ammeters shunts &amp; voltmeter multiplier, Dynamometer type wattmeter, Power factor meter, Instrument transformer. Measurements of R, L and C.</p>	08
5	<p><b>Potentiometers, Bridges and Transducers:</b>  <b>Potentiometers:</b> Basic potentiometer circuit, calibration of ammeter, voltmeter and wattmeter.  <b>Bridges:</b> Wheatstone, Kelvin's double bridge, Maxwell's bridge, Schering Bridge, Q meter.  <b>Transducers:</b> Classification of transducers, Selection of transducers, Resistive, capacitive &amp; inductive transducers, Piezoelectric, Hall effect, Optical and digital transducers.  <b>Measurement of non-electrical quantities:</b> Basic principles of: temperature (Thermistor and Thermo couple), pressure (strain-gauge, capacitive and inductive type) and speed (Inductive and Hall Effect).  Basic requirements of signal conditioning circuits. Amplifier, Filter, and linearization circuit.  <b>Self-study:</b> Hay's bridge, Anderson's bridge, velocity, force and torque measurement.</p>	10
6	<p><b>Digital Measurements:</b> Advantages of digital meters over analog meters, Resolution &amp; sensitivity of digital meters, Working principles of digital Voltmeter, Ammeter, Multi-meter. Working principles and features of Digital Tachometer, Digital Megger, and Digital Storage Oscilloscope.  Introduction to MEMS (micro-electromechanical systems) technology and their applications in electrical and automotive domain.</p>	08

**Assessment:**

**Internal Assessment Test:**

Assessment consists of two class tests of 20 marks each. The first class test (Internal Assessment- I) is to be conducted when approx. 40% syllabus is completed and second class test (Internal Assessment-II) when additional 40% (approx.) syllabus is completed. Duration of each test shall be one hour.

**End Semester Theory Examination:**

1. Question paper will comprise of total 06 questions, each carrying 20 marks.
2. Total 04 questions need to be solved.
3. Question No: 01 will be compulsory and based on entire syllabus wherein 4 sub-questions of 5 marks each will be asked.
4. Remaining questions will be randomly selected from all the modules.
5. Weightage of each module will be proportional to number of respective lecture hours as mentioned in the syllabus.

**Books Recommended:**

**Text Books:**

1. Bimbhra P. S., *Electric Machinery*, Khanna Publisher,
2. Bimbhra P. S., *Generalized Machine Theory*, Khanna Publisher,
3. S. K. Pillai, *A first course on Electrical Drives*, New Age Publication
4. V. K. Mehta, *Principles of Electrical Machines*, S Chand Publications
5. AK Sawhney, *Electrical & Electronic Measurements and Instrumentation*, Dhanpat Rai & Sons
6. Helfric and Cooper, *Modern Electronic Instrumentation and Measurement Techniques*, PHI

7. H.S.Kalsi, *Electronic Instrumentation*, Third Edition, Tata McGraw Hill
8. Ramon Pallaá S-Areny and J. G. Webster, *Sensors And Signal Conditioning*, Second Edition, John Wiley & Sons, Inc.

**Reference Books:**

1. M. G. Say and E. O. Taylor, *Direct current machines*, Pitman publication
2. Ashfaq Husain, *Electric Machines*, Dhanpat Rai and Co. Publications
3. Alan.S.Moris, *Principle of Measurement & Instrumentation*, Prentice Hall of India
4. RS Sirohi & Radhakrisnan, *Electrical Measurement & Instrumentation*, New Age International
5. M. V. Deshpande, *Electric Machines*, PHI
6. Vedam Subramanyam, *Electrical Drive-concept and applications*, TMH Publication
7. Sabrie Soloman, *Sensors Handbook*, Second Edition, McGraw Hill

**NPTEL/ Swayam Course:**

**Course: Electrical Machines – I By Prof. Tapas Kumar Bhattacharya (IIT Kharagpur)**

**[https://swayam.gov.in/nd1\\_noc20\\_ee60/preview](https://swayam.gov.in/nd1_noc20_ee60/preview)**





## UNIT III

### DC GENERATORS

#### Principle of Operation of a D.C. Generator

All the generators work on a principle of dynamically induced e.m.f. This principle nothing but the Faraday's law of electromagnetism induction. It states that, 'whenever the number of magnetic lines of force i.e. flux linking with a conductor or a coil changes, an electromotive force is set up in that conductor or coil.' The change in flux associated with the conductor can exist only when there exists a relative motion between a conductor and the flux. The relative motion can be achieved by rotating conductor with respect to flux or by rotating flux with respect to a conductor. So a voltage gets generated in a conductor, as long as there exists a relative motion between conductor and the flux.

Such an induced e.m.f. which is due to the physical movement of coil or conductor with respect to flux or movement of flux with respect to coil or conductor is called dynamically induced e.m.f.

#### **Key Point:**

So a generating action requires following basic components to exist,

- i) The conductor or a coil
- ii) The relative motion between conductor and flux.

In a particular generator, the conductors are rotated to cut the magnetic flux, keeping flux stationary. To have a large voltage as the output, the number of conductors are connected together in a specific manner, to form a winding. This winding is called armature winding of a d.c. machine. The part on which this winding is kept is called armature of a d.c. machine. To have the rotation of conductors, the conductors placed on the armature are rotated with the help of some external device. Such an external device is called a prim mover. The commonly used prim movers are diesel engines, steam engines, steam turbines, water turbines etc. The necessary magnetic flux is produced by current carrying winding which is called field winding. The direction of the induced e.m.f. can be obtained by using Fleming's right hand rule.

#### Single Loop DC Generator

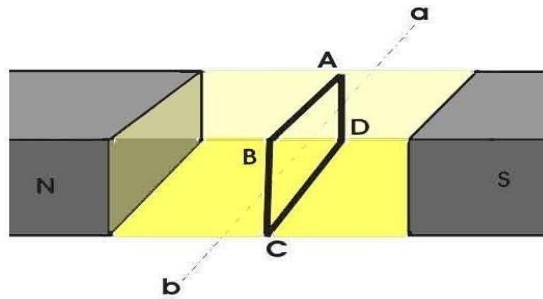

Figure: Single Loop Generator

In the figure above, a single loop of conductor of rectangular shape is placed between two opposite poles of magnet.

Let's us consider, the rectangular loop of conductor is ABCD which rotates inside the magnetic field about its own axis ab. When the loop rotates from its vertical position to its horizontal position, it cuts the flux lines of the field. As during this movement two sides, i.e. AB and CD of the loop cut the flux lines there will be an emf induced in these both of the sides (AB and BC) of the loop.

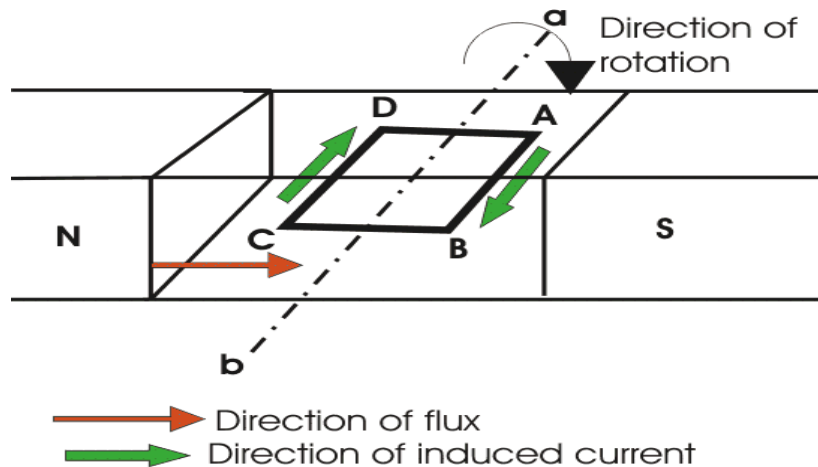

Figure: Single Loop Generator

As the loop is closed there will be a current circulating through the loop. The direction of the current can be determined by Fleming's right hand Rule. This rule says that if you stretch thumb, index finger and middle finger of your right hand perpendicular to each other, then thumbs indicates the direction of motion of the conductor, index finger indicates the direction of magnetic field i.e. N - pole to S - pole, and middle finger indicates the direction of flow of current through the conductor.

Now if we apply this right hand rule, we will see at this horizontal position of the loop, current will flow from point A to B and on the other side of the loop current will flow from point C to D.

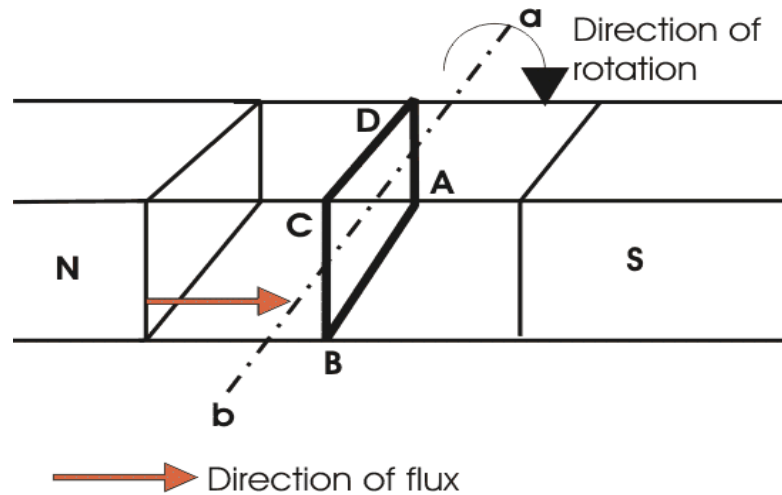

Figure: Single Loop Generator

Now if we allow the loop to move further, it will come again to its vertical position, but now upper side of the loop will be CD and lower side will be AB (just opposite of the previous vertical position). At this position the tangential motion of the sides of the loop is parallel to the flux lines of the field. Hence there will be no question of flux cutting and consequently there will be no current in the loop. If the loop rotates further, it comes to again in horizontal position. But now, said AB side of the loop comes in front of N pole and CD comes in front of S pole, i.e. just opposite to the previous horizontal position as shown in the figure beside.

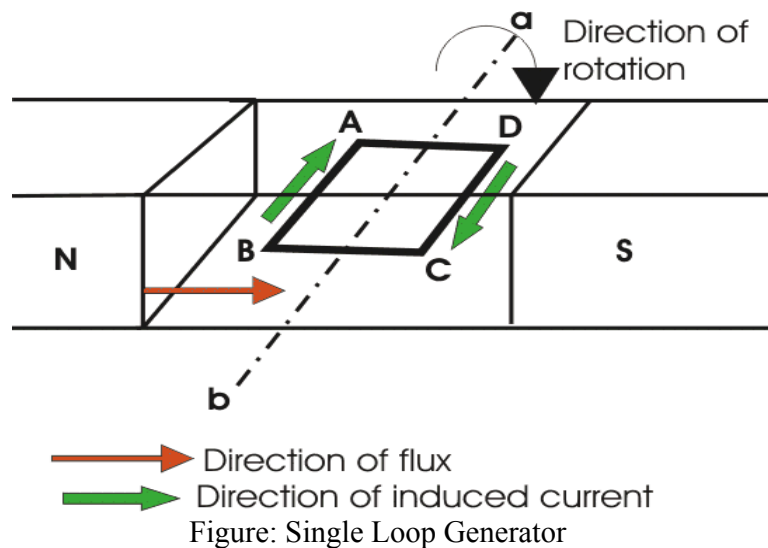

Figure: Single Loop Generator

Here the tangential motion of the side of the loop is perpendicular to the flux lines, hence rate of flux cutting is maximum here and according to Fleming's right hand Rule, at this position current flows from

B to A and on other side from D to C. Now if the loop is continued to rotate about its axis, every time the side AB comes in front of S pole, the current flows from A to B and when it comes in front of N pole, the current flows from B to A. Similarly, every time the side CD comes in front of S pole the current flows from C to D and when it comes in front of N pole the current flows from D to C.

If we observe this phenomena in different way, it can be concluded, that each side of the loop comes in front of N pole, the current will flow through that side in same direction i.e. downward to the reference plane and similarly each side of the loop comes in front of S pole, current through it flows in same direction i.e. upwards from reference plane. From this, we will come to the topic of principle of DC generator. Now the loop is opened and connected it with a split ring as shown in the figure below. Split ring are made out of a conducting cylinder which cuts into two halves or segments insulated from each other. The external load terminals are connected with two carbon brushes which are rest on these split slip ring segments.

### Working Principle of DC Generator

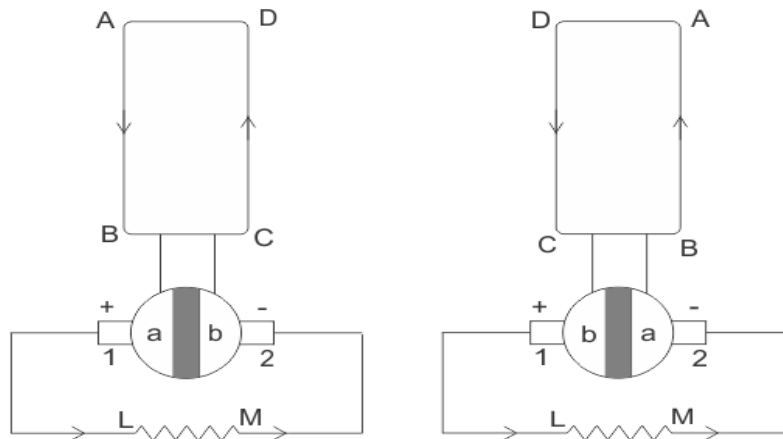

Fig: Commutation action

It is seen that in the first half of the revolution current flows always along ABLMCD i.e. brush no 1 in contact with segment a. In the next half revolution, in the figure the direction of the induced current in the coil is reversed. But at the same time the position of the segments a and b are also reversed which results that brush no 1 comes in touch with the segment b. Hence, the current in the load resistance again flows from L to M. The wave form of the current through the load circuit is as shown in the figure. This current is unidirectional.

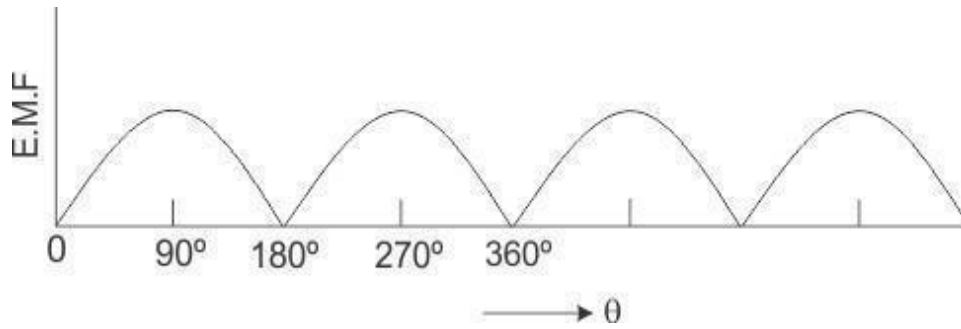

Fig: Output waveform of generator

This is basic working principle of DC generator, explained by single loop generator model. The position of the brushes of DC generator is so arranged that the change over of the segments a and b from one brush to other takes place when the plane of rotating coil is at right angle to the plane of the lines of force. It is so become in that position, the induced emf in the coil is zero.

### Construction of a DC Machine:

A DC generator can be used as a DC motor without any constructional changes and vice versa is also possible. Thus, a DC generator or a DC motor can be broadly termed as a DC machine. These basic constructional details are also valid for the construction of a DC motor. Hence, let's call this point as construction of a DC machine instead of just 'construction of a DC generator.

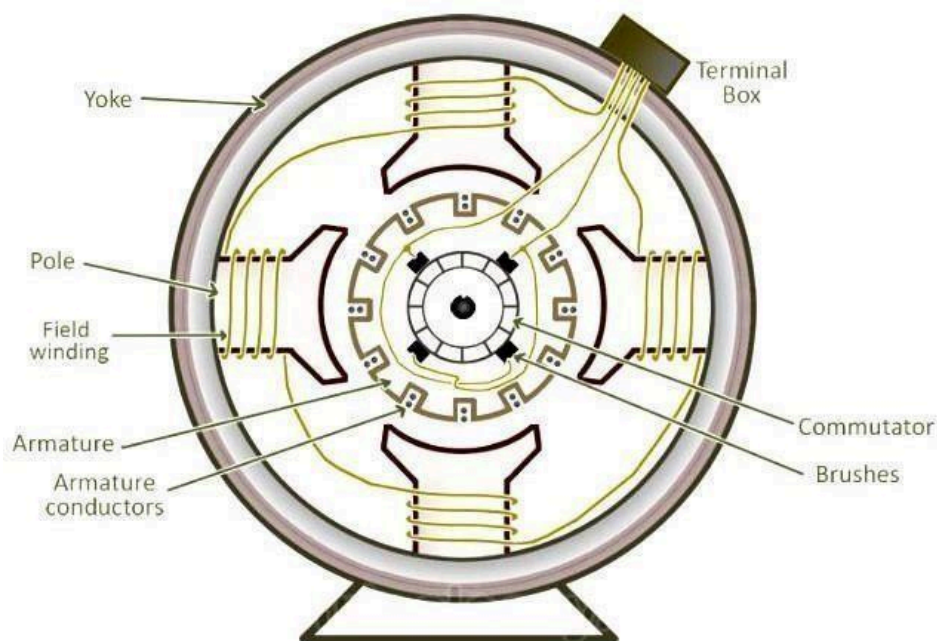

Figure 1: constructional details of a simple 4-pole DC machine

The above figure shows constructional details of a simple 4-pole DC machine. A DC machine consists of two basic parts; stator and rotor. Basic constructional parts of a DC machine are described below.

1. **Yoke:** The outer frame of a dc machine is called as yoke. It is made up of cast iron or steel. It not only provides mechanical strength to the whole assembly but also carries the magnetic flux produced by the field winding.
2. **Poles and pole shoes:** Poles are joined to the yoke with the help of bolts or welding. They carry field winding and pole shoes are fastened to them. Pole shoes serve two purposes; (i) they support field coils and (ii) spread out the flux in air gap uniformly.

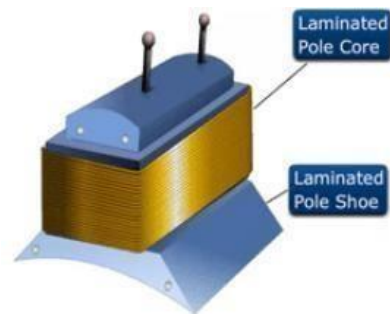

Figure 2: Pole Core and Poles Shoes representation

3. **Field winding:** They are usually made of copper. Field coils are former wound and placed on each pole and are connected in series. They are wound in such a way that, when energized, they form alternate North and South poles.
4. **Armature core:** Armature core is the rotor of a dc machine. It is cylindrical in shape with slots to carry armature winding. The armature is built up of thin laminated circular steel disks for reducing eddy current losses. It may be provided with air ducts for the axial air flow for cooling purposes. Armature is keyed to the shaft.

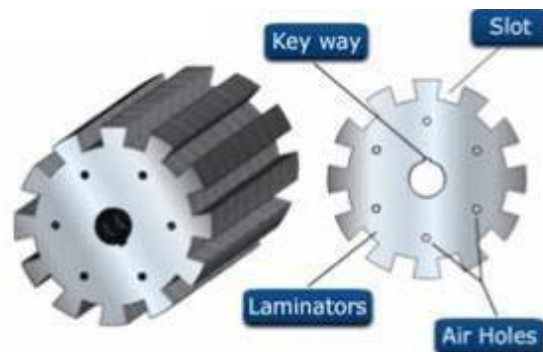

Figure 3: Armature of DC machine

- 5. Armature winding:** It is usually a former wound copper coil which rests in armature slots. The armature conductors are insulated from each other and also from the armature core. Armature winding can be wound by one of the two methods; lap winding or wave winding. Double layer lap or wave windings are generally used. A double layer winding means that each armature slot will carry two different coils.

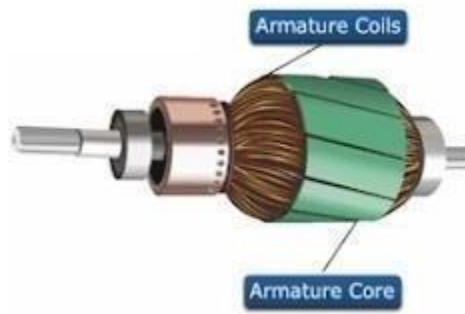

Figure 4: Armature Winding/coil of DC machine

- 6. Commutator and brushes:** Physical connection to the armature winding is made through a commutator-brush arrangement. The function of a commutator, in a dc generator, is to collect the current generated in armature conductors. Whereas, in case of a dc motor, commutator helps in providing current to the armature conductors. A commutator consists of a set of copper segments which are insulated from each other. The number of segments is equal to the number of armature coils. Each segment is connected to an armature coil and the commutator is keyed to the shaft. Brushes are usually made from carbon or graphite. They rest on commutator segments and slide on the segments when the commutator rotates keeping the physical contact to collect or supply the current.

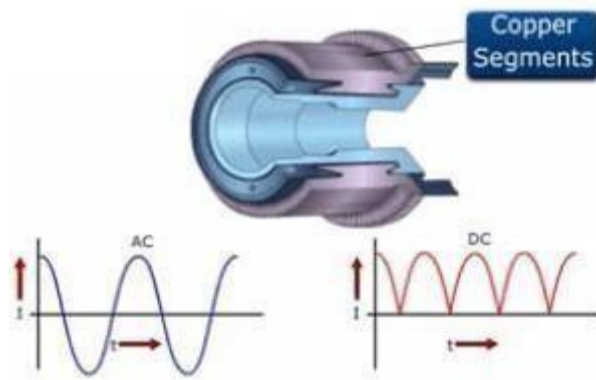

Figure 5: Commutator of DC machine

### **Armature Winding Terminology:**

Now we are going to discuss about armature winding in details. Before going through this section, we should understand some basic terms related to armature winding of DC generator.

#### **Pole Pitch:**

The pole pitch is defined as peripheral distance between centers of two adjacent poles in DC machine. This distance is measured in term of armature slots or armature conductor come between two adjacent pole centers. Pole Pitch is naturally equal to the total number of armature slots divided by the number of poles in the machine.

If there are 96 slots on the armature periphery and 4 numbers of poles in the machine, the numbers of armature slots come between two adjacent poles centres would be  $96/4 = 24$ . Hence, the pole pitch of that

---

DC machine would be 24.



As we have seen that, pole pitch is equal to total numbers of armature slots divided by total numbers of poles, we alternatively refer it as armature slots per pole.

### Coil side:

Coil of dc machine is made up of one turn or multi turns of the conductor. If the coil is made up of single turn or a single loop of conductor, it is called single turn coil. If the coil is made up of more than one turn of a conductor, we refer it as a multi-turn coil. A single turn coil will have one conductor per side of the coil whereas, in multi turns coil, there will be multiple conductors per side of the coil. Whatever may be the number of conductors per side of the coil, each coil side is placed inside one armature slot only. That means all conductors of one side of a particular coil must be placed in one single slot only. Similarly, we place all conductors of opposite side of the coil in another single armature slot.

### Coil Span

Coil span is defined as the peripheral distance between two sides of a coil, measured in term of the number of armature slots between them. That means, after placing one side of the coil in a particular slot, after how many conjugative slots, the other side of the same coil is placed on the armature. This number is known as coil span.

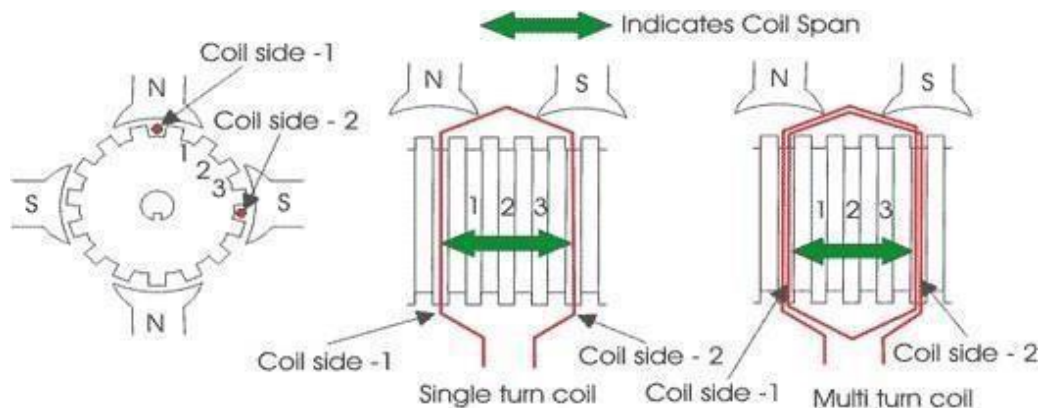

Figure: Armature windings

If the coil span is equal to the pole pitch, then the armature winding is said to be full - pitched. In this situation, two opposite sides of the coil lie under two opposite poles. Hence emf induced in one side of the coil will be in  $180^\circ$  phase shift with emf induced in the other side of the coil. Thus, the total terminal voltage of the coil will be nothing but the direct arithmetic sum of these two emfs. If the coil span is less than the pole pitch, then the winding is referred as fractional pitched. In this coil, there will be a phase difference between induced emf in two sides, less than  $180^\circ$ . Hence resultant terminal voltage of the coil is vector sum of these two emf's and it is less than that of full-pitched coil.

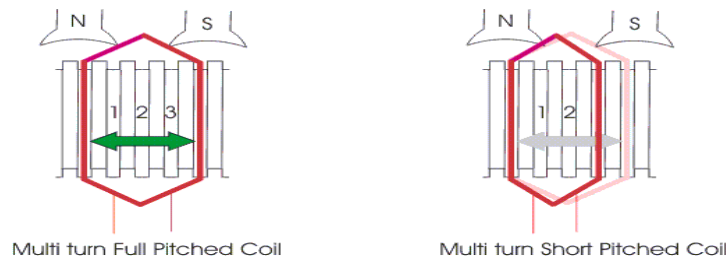
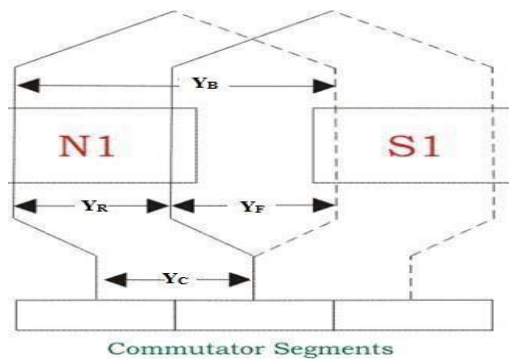

Figure: full pitched and half pitched coils

In practice, coil pitch (or Span) as low as eight tenth of a Pole Pitch, is employed without much serious reduction in emf. Fractional pitched windings are purposely used to effect substantial saving in copper of the end connection and for improving commutation.

**Pitch of Armature Winding**



**Back Pitch ( $Y_B$ )**

A coil advances on the back of the armature. This advancement is measured in terms of armature conductors and is called back pitch. It is equal to the number difference of the conductor connected to a given segment of the commutator.

**Front Pitch ( $Y_F$ )**

The number of armature conductors or elements spanned by a coil on the front is called front pitch. Alternatively, we define the front-pitch as the distance between the second conductor of the next coil which connects the front, i.e., commutator end of the armature. In other words, it is the number difference of the conductors connected together at the back end of the armature. We are showing both front and back pitches for a lap, and a wave windings in the figure below.

**Resultant Pitch ( $Y_R$ )**

It is the distance between the beginning of one coil and the beginning of the next coil to which it is connected. As a matter of precautions, we should keep in mind that all these pitches, though normally stated concerning armature conductors, are also times of armature slots or commutator bars.

### **Commutator Pitch ( $Y_c$ )**

Commutator pitch is defined as the distance between two commutator segments which two ends of same armature coil are connected. We measure commutator pitch in term of commutator bars or segment.

### **Single Layer Armature Winding**

We place armature coil sides in the armature slots differently. In some arrangement, each one side of an armature coil occupies a single slot. In other words, we place one coil side in each armature slot. We refer this arrangement as single layer winding.

### **Two Layer Armature Winding**

In other types of armature winding, arrangement two coil sides occupy every armature slot; one occupies upper half, and another one occupies the lower half of the slot. We so place the coils in two layers winding that if one side occupies upper half, then another side occupies the lower half of some other slot at a distance of one coil pitch away.

### **Armature Winding of A DC Machine**

Based on type of winding connections we classified armature winding of a dc machine into two types.

These winding connections are same for DC generator & DC motor.

Types of Windings in DC Machine,

1. Lap winding.
2. Wave winding.

### **Lap winding of a DC Machine**

In this type of winding the completing end of one coil is connected to a commutator segment and to the start end of adjacent coil located under the same pole and similarly all coils are connected. This type of winding is known as lap because the sides of successive coils overlap each other.

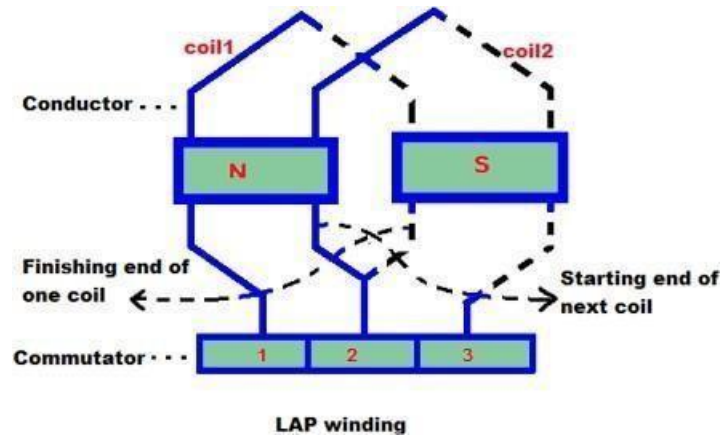

Lap winding may be simplex (single) or multiplex (duplex or triplex) winding. In simplex lap winding the connection of the winding is that there are as many parallel paths as there are number of poles.

Whereas for duplex, the number of parallel paths are equal to twice that of the number of poles and for triplex it is thrice. For this reason, the lap winding is called multiple or parallel winding. The sole purposes of such type of windings are,

- (a) To increase the number of parallel paths enabling the armature current to increase i.e., for high current output.
- (b) To improve commutation as the current per conductor decreases.

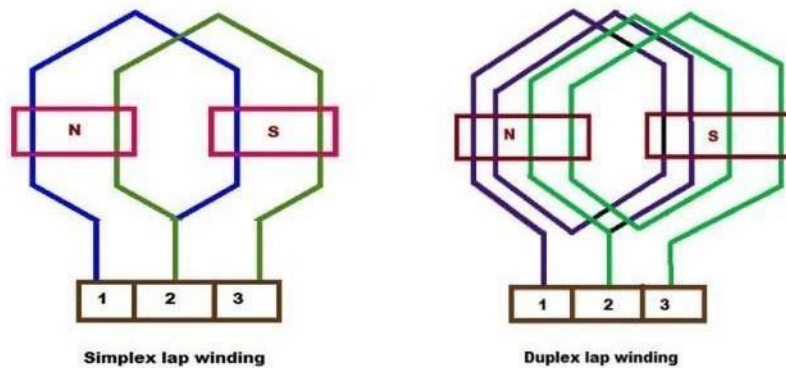

### Notes on Lap winding

- 
1. The coil or back pitch  $Y_B$  must be approximately equal to pole pitch i.e.,  $Y_B = Z/P$ .

- The back pitch and front pitch are odd and are of opposite sign. They differ from each other by  $2m$ , where  $m = 1, 2, 3$  for simplex, duplex, and triplex respectively.

i.e.,  $Y_B = Y_F \pm 2m$

When  $Y_B > Y_F$  i.e.,  $Y_F + 2m$  then the winding progresses from left to right and such a winding is known as progressive winding. If  $Y_B < Y_F$  i.e.,  $Y_B = Y_F - 2m$  then the winding progresses from right to left and such a winding is known as retrogressive winding.

- The average pitch,  $Y_{AVE} = (Y_B + Y_F)/2$ .
- Resultant pitch,  $Y_R$  is always even as difference between two odd numbers is even and is equal to  $2m$ .
- Commutator pitch,  $Y_C = m$  i.e., 2, 3, 4 etc. for simplex, duplex, triplex, quadruplex etc.
- Number of parallel paths =  $mP$ . Where,  $m$  = multiplicity.

Example: For instance, the number of parallel paths for a 6-pole duplex lap winding is given by  $6 \times 2 = 12$  paths.

- The total number of poles are equal to the total number of brushes.
- If  $I_a$  is the total armature current, then current per parallel path is  $I_a / P$ .
- Lap winding is used for low voltage and high current machines.

### Wave winding of a DC Machine

In wave winding the coils which are carrying current in one direction are connected in series circuit and the carrying current in opposite direction are connected in another series circuit. A wave winding is shown in figure.

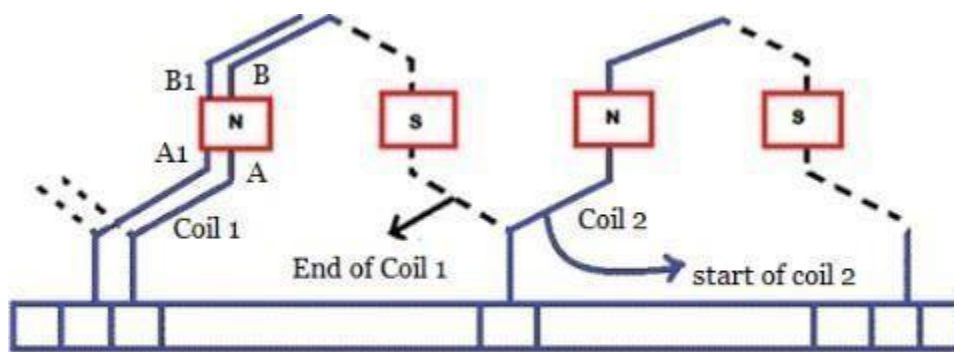

Wave Winding

If after passing once around the armature the winding falls in a slot to the left of its starting point then winding is said to be retrogressive. If it falls one slot to the right it is progressive.

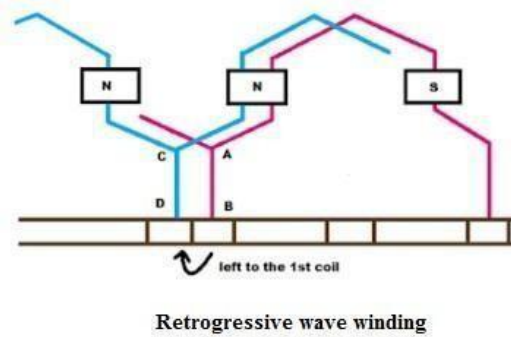
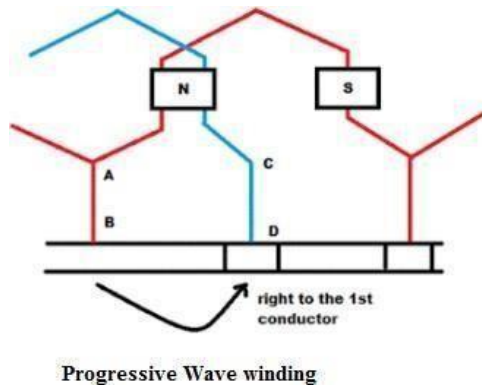

### Notes on Wave winding

The following are the important points to be remembered pertaining to wave winding,

1. Both pitches  $Y_B$  and  $Y_F$  are odd and of same sign.
2. Back and front pitches may be equal or differ by 2 and are merely equal to pole pitch.
3. Resultant pitch,  $Y_R = Y_F + Y_B = (Z \pm 2)/2$   $P =$  Number of poles  
 $Z =$  Total number of conductors.
4. Commutator pitch,  $Y_C = Y_A$  (Averagepitch)  
 $Y_C = (\text{Number of commutator bars} \pm 1) / (\text{Number of pair of poles})$ .
5. Number of parallel paths are equal to  $2m$ , where  $m$  is the multiplicity.
6. The number of brushes required are two irrespective of the number of poles.
7. If  $I_a$  is the total armature current then current carried by each path or conductor is  $I_a/2$ .
8. Since a wave winding is a series winding, it is used for high voltage and low current machine.

### Emf Equation of a DC Generator

As the armature rotates, a voltage is generated in its coils. In the case of a generator, the emf of rotation is called the Generated emf or Armature emf and is denoted as  $E_r = E_g$ . In the case of a motor, the emf of rotation is known as Back emf or Counter emf and represented as  $E_r = E_b$ . The expression for emf is same for both the operations. I.e., for Generator as well as for Motor

### **Derivation of EMF Equation of a DC Machine – Generator and Motor**

Let,

- $P$  – Number of poles of the machine

- $\phi$  – Flux per pole in Weber.
- $Z$  – Total number of armature conductors.
- $N$  – Speed of armature in revolution per minute (r.p.m).
- $A$  – Number of parallel paths in the armature winding.

In one revolution of the armature, the flux cut by one conductor is given as

$$\text{Flux cut by one conductor} = P\phi \text{ wb} \dots \dots (1)$$

Time taken to complete one revolution is given as

$$t = \frac{60}{N} \text{ seconds} \dots \dots (2)$$

Therefore, the average induced e.m.f in one conductor will be

$$e = \frac{P\phi}{t} \dots \dots (3)$$

Putting the value of (t) from Equation (2) in the equation (3) we will get

$$e = \frac{P\phi}{60/N} = \frac{P\phi N}{60} \text{ volts} \dots \dots (4)$$

The number of conductors connected in series in each parallel path =  $Z/A$ .

Therefore, the average induced e.m.f across each parallel path or the armature terminals is given by the equation shown below.

$$E = \frac{P\phi N}{60} \times \frac{Z}{A} = \frac{PZ\phi N}{60 A} \text{ volts or}$$

$$E = \frac{PZ\phi n}{A} \dots\dots (5)$$

Where n is the speed in revolution per second (r.p.s) and given as

$$n = \frac{N}{60}$$

For a given machine, the number of poles and the number of conductors per parallel path (Z/A) are constant. Hence, the equation (5) can be written as

$$E = K\phi n$$

Where, K is a constant and given as

$$K = \frac{PZ}{A}$$

Therefore, the average induced emf equation can also be written as

$$E \propto \phi n \text{ or}$$

$$E = K_1 \phi N$$

Where K<sub>1</sub> is another constant and hence induced emf equation can be written as

$$E \propto \phi N \text{ or}$$

$$E \propto \phi \omega$$

---



Where  $\omega$  is the angular velocity in radians/second is represented as

$$\omega = \frac{2\pi N}{60}$$

Thus, it is clear that the induced emf is directly proportional to the speed and flux per pole. The polarity of induced emf depends upon the direction of the magnetic field and the direction of rotation. If either of the two is reverse the polarity changes, but if two are reversed the polarity remains unchanged.

This induced emf is a fundamental phenomenon for all the DC Machines whether they are working as a generator or motor.

If the machine DC Machine is working as a Generator, the induced emf is given by the equation shown below.

$$E_g = \frac{PZ \phi N}{60 A} \quad \text{volts}$$

Where  $E_g$  is the **Generated Emf**

If the machine DC Machine is working as a Motor, the induced emf is given by the equation shown below.

$$E_b = \frac{PZ \phi N}{60 A} \quad \text{volts}$$

In a motor, the induced emf is called **Back Emf ( $E_b$ )** because it acts opposite to the supply voltage.

### **Armature Reaction in DC Machines**

In a DC machine, two kinds of magnetic fluxes are present; 'armature flux' and 'main field flux'. The effect of armature flux on the main field flux is called as armature reaction.

### **MNA And GNA**

EMF is induced in the armature conductors when they cut the magnetic field lines. There is an axis (or,

you may say, a plane) along which armature conductors move parallel to the flux lines and, hence, they do not cut the flux lines while on that plane. MNA (Magnetic Neutral Axis) may be defined as the axis along which no emf is generated in the armature conductors as they move parallel to the flux lines. Brushes are always placed along the MNA because reversal of current in the armature conductors takes place along this axis.

GNA (Geometrical Neutral Axis) may be defined as the axis which is perpendicular to the stator field axis.

### Armature Reaction

The effect of armature reaction is well illustrated in the figure below.

Consider, no current is flowing in the armature conductors and only the field winding is energized (as shown in the first figure of the above image). In this case, magnetic flux lines of the field poles are uniform and symmetrical to the polar axis. The 'Magnetic Neutral Axis' (M.N.A.) coincides with the 'Geometric Neutral Axis' (G.N.A.).

The second figure in the above image shows armature flux lines due to the armature current. Field poles are de-energised

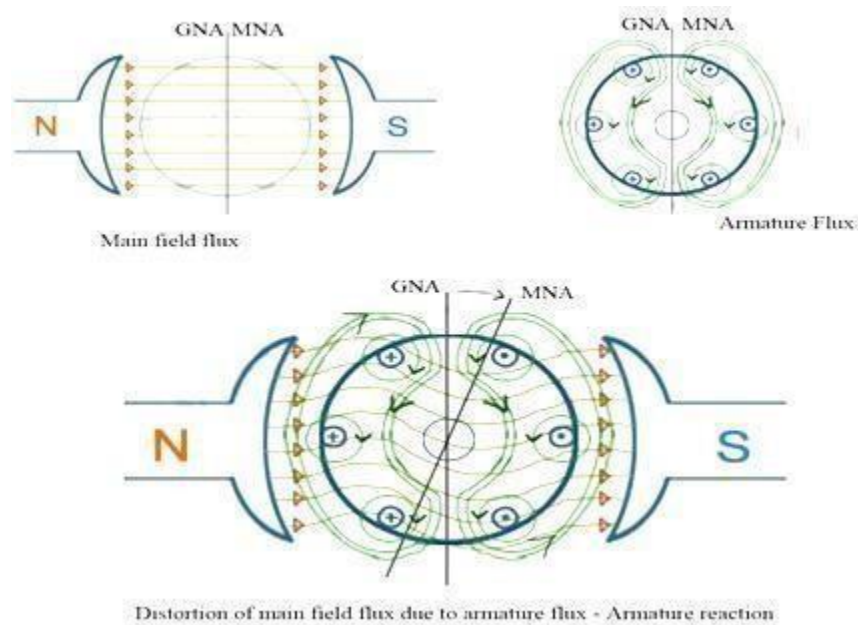

Fig: Armature reaction

Now, when a DC machine is running, both the fluxes (flux due to the armature conductors and flux due to the field winding) will be present at a time. The armature flux superimposes with the main field flux and, hence, disturbs the main field flux (as shown in third figure the of above image). This effect is called

as armature reaction in DC machines.

### **The Adverse Effects Of Armature Reaction:**

1. Armature reaction weakens the main flux. In case of a dc generator, weakening of the main flux reduces the generated voltage.
2. Armature reaction distorts the main flux, hence the position of M.N.A. gets shifted (M.N.A. is perpendicular to the flux lines of main field flux). Brushes should be placed on the M.N.A., otherwise, it will lead to sparking at the surface of brushes. So, due to armature reaction, it is hard to determine the exact position of the MNA

For a loaded dc generator, MNA will be shifted in the direction of the rotation. On the other hand, for a loaded dc motor, MNA will be shifted in the direction opposite to that of the rotation.

### **How To Reduce Armature Reaction?**

Usually, no special efforts are taken for small machines (up to few kilowatts) to reduce the armature reaction. But for large DC machines, compensating winding and interpoles are used to get rid of the ill effects of armature reaction.

**Compensating winding:** Now we know that the armature reaction is due to the presence of armature flux. Armature flux is produced due to the current flowing in armature conductors. Now, if we place another winding in close proximity of the armature winding and if it carries the same current but in the opposite direction as that of the armature current, then this will nullify the armature field. Such an additional winding is called as compensating winding and it is placed on the pole faces. Compensating winding is connected in series with the armature winding in such a way that it carries the current in opposite direction.

**Interpoles:** Interpoles are the small auxiliary poles placed between the main field poles. Winding on the interpoles is connected in series with the armature. Each interpole is wound in such a way that its magnetic polarity is same as that of the main pole ahead of it. Interpoles nullify the quadrature axis armature flux.

---

## Demagnetizing and Cross Magnetizing Conductors

The conductors w  
the Fig.1.

zing and distortion effects are shown in

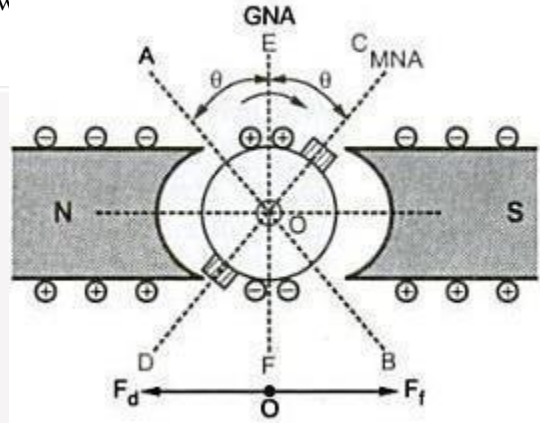
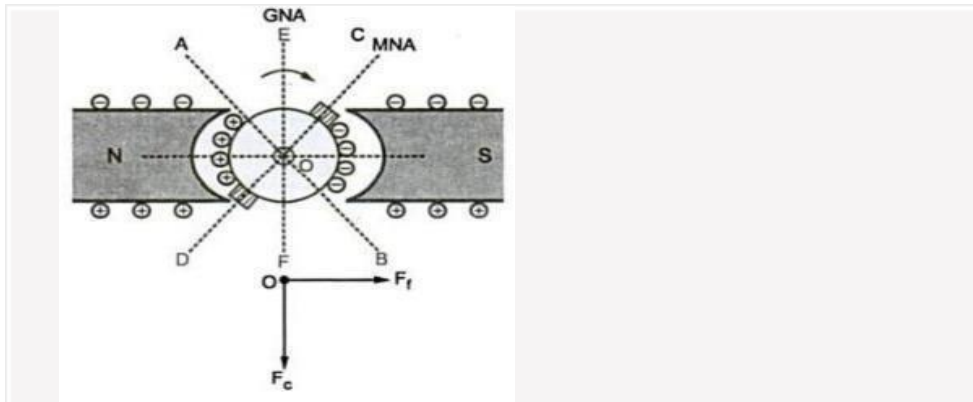

**Fig. 1** Conductors which are responsible for producing demagnetizing and distortion effects

The brushes are lying along the new position of MNA which is at angle  $\theta$  from GNA. The conductors in the region  $AOC = BOD = 2\theta$  at the top and bottom of the armature are carrying current in such a direction as to send the flux in armature from right to left. Thus these conductors are in direct opposition to main field and called demagnetizing armature conductors.

The remaining armature conductors which are lying in the region AOD and BOC carry current in such a direction as to send the flux pointing vertically downwards i.e. at right angles to the main field flux. Hence these conductors are called cross magnetizing armature conductors which will cause distortion in main field flux.

These conductors are shown in the Fig. 2



**Fig. 2** Conductors which are responsible for producing Cross magnetization effects

### Calculation of Demagnetizing and Cross Magnetizing Amp-Turns

Let us the number of demagnetizing and cross magnetizing amp-turns. Let  $Z$  = Total number of armature conductors

$P$  = Number of poles

$I$  = Armature conductor current in Amperes

=  $I_a/2$  for simplex wave winding

=  $I_a/P$  for simplex lap winding

$\theta_m$  = Forward lead of brush in mechanical degrees.

The conductors which are responsible for demagnetizing ampere-turns are lying in the region spanning  $4\theta_m$  degrees. The region is between angles AOC and BOD, as shown in the Fig. 2.

$\therefore$  Total number of armature conductors lying in angles AOC and BOD.

$$= \frac{4\theta_m}{360} \times Z$$

Since two conductors from one turn,

$$\begin{aligned} \text{Total number of turns in these angles} &= \frac{1}{2} \cdot \frac{4\theta_m}{360} \times Z \\ &= \frac{2\theta_m}{360} \times Z \end{aligned}$$

$$\therefore \text{Demagnetising amp-turns} = \frac{2\theta_m}{360} \times IZ$$

$$\therefore \text{Demagnetising amp-turns / pole} = \frac{\theta_m}{360} \times IZ$$

$$\therefore \boxed{\text{AT}_d \text{ per pole} = ZI \times \frac{\theta_m}{360}}$$

The conductor which are responsible for cross magnetizing ampere turns are lying between the angles AOD and BOC, as shown in the Fig.2.

$$\text{Total armature-conductors / pole} = Z/P$$

From above we have found an expression for demagnetizing conductors per pole.

$$\text{Demagnetising conductors / pole} = Z = \frac{2\theta_m}{360}$$

$$\begin{aligned} \therefore \text{Cross magnetising conductors/pole} &= \frac{Z}{P} - Z \frac{2\theta_m}{360} \\ &= Z \left[ \frac{1}{P} - \frac{2\theta_m}{360} \right] \end{aligned}$$

$$\therefore \text{Cross magnetising amp-conductors / pole} = ZI \left[ \frac{1}{P} - \frac{2\theta_m}{360} \right]$$

Since two conductors from one turn,

$$\begin{aligned} \text{Cross magnetising amp-turns / pole} &= \frac{1}{2} \cdot ZI \left[ \frac{1}{P} - \frac{2\theta_m}{360} \right] \\ &= ZI \left[ \frac{1}{2P} - \frac{\theta_m}{360} \right] \end{aligned}$$

$$\therefore \text{AT}_c \text{ per pole} = ZI \left[ \frac{1}{2P} - \frac{\theta_m}{360} \right]$$

If the brush shift angle is given in electrical degrees then it should be converted into mechanical degrees by using the relation,

$$\theta_{\text{mechanical}} = \frac{\theta_{\text{electrical}}}{\text{Pair of poles}} = \frac{\theta_{\text{electrical}}}{P/2} = \frac{2\theta_{\text{electrical}}}{P}$$

**Example :**

A wave wound 4 pole d.c. generator with 480 armature conductors supplies a current of 144 A. The brushes are given an actual lead of  $10^\circ$ . Calculate the demagnetizing and cross magnetizing amp turns per pole.

**Solution :**

$$P = 4, \quad Z = 480, \quad I_a = 144 \text{ A}$$

For wave wound,

$$I = I_a/2 = 144/2 = 72 \text{ A}$$

$$\theta_m = 10^\circ$$

$$\begin{aligned} \text{AT}_d/\text{pole} &= ZI \frac{\theta_m}{360} \\ &= \frac{480 \times 72 \times 10}{360} \\ &= 960 \end{aligned}$$

$$\begin{aligned} \text{AT}_c/\text{pole} &= ZI \left[ \frac{1}{2P} - \frac{\theta_m}{360} \right] = 480 \times 72 \left[ \frac{1}{2 \times 4} - \frac{10}{360} \right] \\ &= 3360 \end{aligned}$$

## Compensating Winding and Interpoles in DC Generator

In DC compound machine setup by armature current opposes magnetic field flux, this is known as armature reaction. The armature reaction has two effects (i) Demagnetizing effect and (ii) Cross magnetizing effect. Demagnetizing effect weakens the main field flux which in turn decreases the induced e.m.f (as  $E \propto \Phi$ ). To overcome this effect a few extra turns/poles are added in series to main field winding. This creates a series field which serves two purposes,

(i) It helps to neutralize the demagnetizing effect of armature reaction.

(ii) If wound for cumulative compounded machine the electrical performance will be improved.

### Compensating winding:

All armature conductors placed under the main poles region produces e.m.f which is at right angle ( $90^\circ$ ) to the main field e.m.f. This e.m.f causes distortion in main field flux. This is known as cross magnetizing effect. To minimize the cross magnetizing effect compensating winding is used. This compensating winding produces an m.m.f which opposes the m.m.f produced by armature conductors.

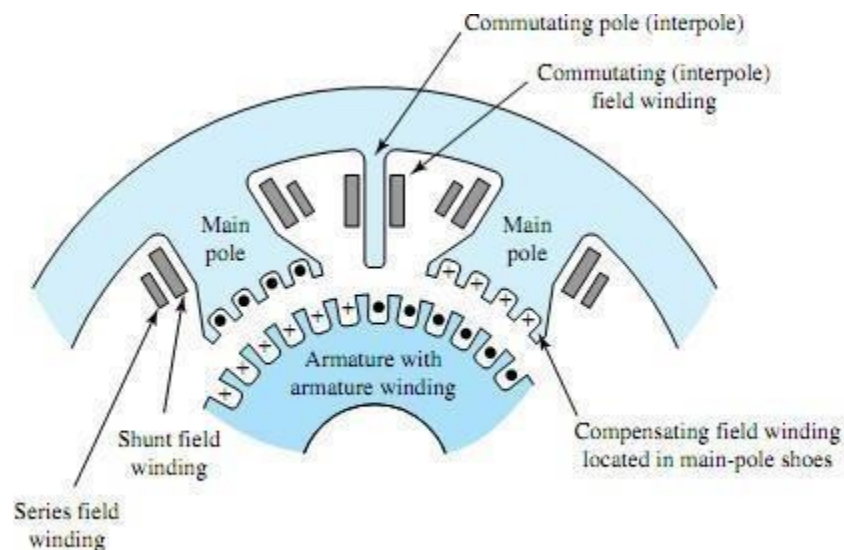

Section of a dc machine illustrating the arrangement of various field windings.

This objective is achieved by connecting compensating winding in series with armature winding. In absence of compensating winding, cross magnetizing effect causes sparking at the commutators and short circuiting the whole armature winding.

Let,  $Z_c$  = Number of compensating conductors/pole

$Z_a$  = Number of active armature



conductors/pole

$I_a$  = Armature current.

$$Z_c I_a = Z_a (I_a / A)$$

Where,

$I_a / A$  = Armature

current/conductor  $Z_c = Z_a / A$

### Compensating Winding Disadvantages

This winding neutralizes the cross magnetizing effect due to armature conductors only but not due to interpolar region. This winding is used in large machine in which load is fluctuating.

### Interpoles

Cross magnetizing effect in interpolar region is by interpoles (also known as compoles (or) commutating poles). These interpoles are small in size and placed in between the main poles of yoke. Like compensating winding, interpoles are also connected in series with armature winding such that the m.m.f produced by them opposes the m.m.f produced by armature conductor in interpolar region. In generators, the interpole polarity is same as that of main pole ahead such that they induce an e.m.f which is known as commutating or reversing e.m.f. This commutating e.m.f minimizes the reactance e.m.f and hence sparks or arcs are eliminated.

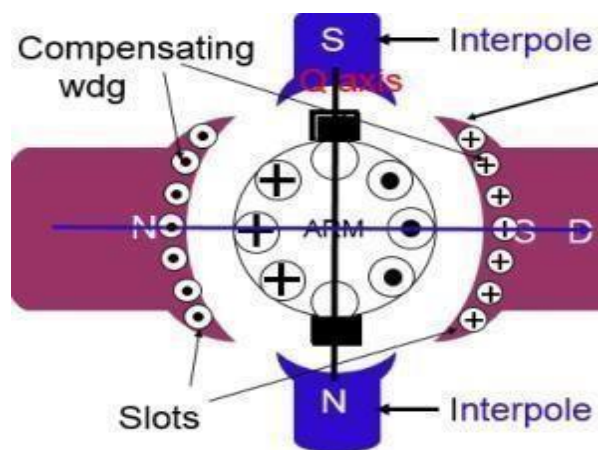

Fig: Intepoles

Compensating winding and Interpoles are used for same purpose but the difference between them is, interpoles produce e.m.f for neutralizing reactance e.m.f whereas compensating winding produces an m.m.f which opposes the m.m.f produced by conductors.

### COMMUTATION:

The process of reversal of current in the short circuited armature coil is called 'Commutation'. This process of reversal takes place when coil is passing through the interpolar axis (q-axis), the coil is short circuited through commutator segments. Commutation takes place simultaneously for 'P' coils in a lap-wound machine and two coil sets of P/2 coils each in a wave-wound machine.

The process of commutation of coil 'B' is shown below. In figure '1.29' coil 'B' carries current from left to right and is about to be short circuited in figure '1.30' brush has moved by 1/3 rd of its width and the brush current supplied by the coil are as shown. In figure '1.31' coil 'B' carries no current as the brush is at the middle of the short circuit period and the brush current is supplied by coil C and coil A. In figure '1.32' the coil B which was carrying current from left to right carries current from right to left. In figure '1.33' spark is shown which is due to the reactance voltage. As the coil is embedded in the armature slots, which has high permeability, the coil possesses appreciable amount of self inductance. The current is changed from +I to -I. So due to self inductance and variation in the current from +I to -I, a voltage is induced in the coil which is given by  $L \frac{di}{dt}$ . Fig '1.34' shows the variation of current plotted on the time axis. Sparking can be avoided by the use of interpoles or commutating-poles.

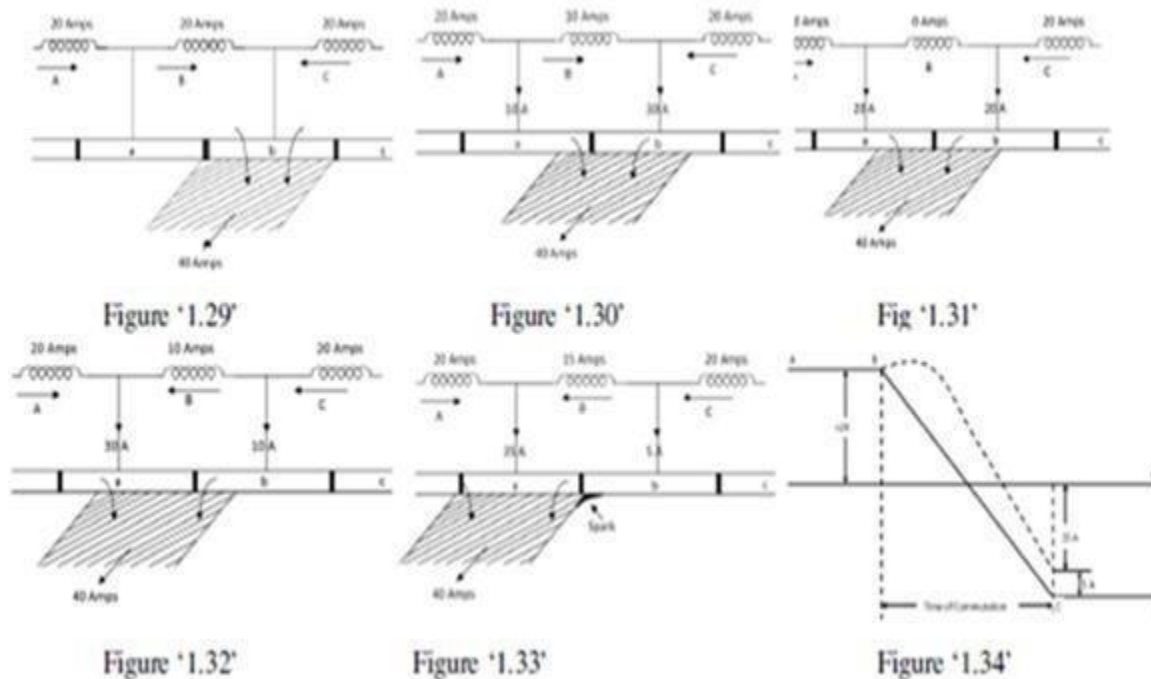

Fig: Commutation process

#### METHODS OF IMPROVING COMMUTATION:

Methods of Improving Commutation: There are two practical ways of improving commutation i.e. of

making current reversal in the short-circuited coil as sparkless as possible. These methods are known as (i) resistance commutation and (ii) emf. commutation (which is done with the help of either brush lead or interpoles, usually the later).

**Resistance Commutation:** This method of improving commutation consists of replacing low-resistance Cu brushes by comparatively high-resistance carbon brushes. When current  $I$  from coil C reach the commutator segment b, it has two parallel paths open to it. The first part is straight from bar 'b' to the brush and the other parallel path is via the short-circuited coil B to bar 'a' and then to the brush. If the Cu brushes are used, then there is no inducement for the current to follow the second longer path, it would preferably follow the first path. But when carbon brushes having high resistance are used, then current  $I$  coming from C will prefer to pass through the second path. The additional advantages of carbon brushes are that (i) they are to some degree self lubricating and polish the commutator and (ii) should sparking occur, they would damage the commutator less than when Cu brushes are used. But some of their minor disadvantages are: (i) Due to their high contact resistance (which is beneficial to sparkless commutation) a loss of approximately 2 volt is caused. Hence, they are not much suitable for small machines where this voltage forms an appreciable percentage loss. (ii) Owing to this large loss, the commutator has to be made somewhat larger than with Cu brushes in order to dissipate heat efficiently without greater rise of temperature. (iii) because of their lower current density (about 7-8 A/cm<sup>2</sup> as compared to 25-30 A/cm<sup>2</sup> for Cu brushes) they need larger brush holders.

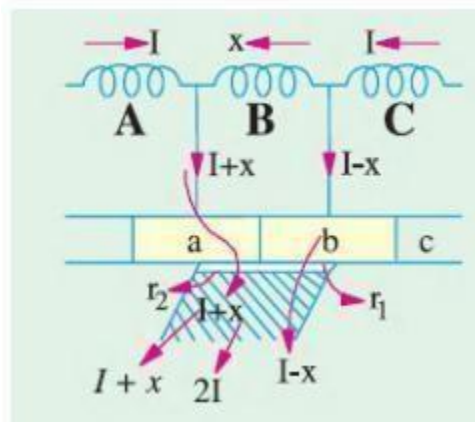

Fig: Resistance Commutation

**EMF Commutation:** In this method, arrangement is made to neutralize the reactance voltage by producing a reversing emf in the short-circuited coil under commutation. This reversing emf, as the name shows, is an emf in opposition to the reactance voltage and if its value is made equal to the latter, it will completely wipe it off, thereby producing quick reversal of current in the short-circuited coil which will result in sparkless commutation. The reversing emf may be produced in two ways: (i) either by giving the

brushes a forward lead sufficient enough to bring the short-circuited coil under the influence of next pole of opposite polarity or (ii) by using Interpoles. The first method was used in the early machines but has now been abandoned due to many other difficulties it brings along with.

**Interpoles of Compoles:** These are small poles fixed to the yoke and spaced in between the main poles. They are wound with comparatively few heavy gauge Cu wire turns and are connected in series with the armature so that they carry full armature current. Their polarity, in the case of a generator, is the same as that of the main pole ahead in the direction of rotation. The function of interpoles is two-fold: (i) As their polarity is the same as that of the main pole ahead, they induce an emf in the coil (under commutation) which helps the reversal of current. The emf induced by the compoles is known as commutating or reversing emf. The commutating emf neutralizes the reactance emf thereby making commutation sparkless. With interpoles, sparkless commutation can be obtained up to 20 to 30% overload with fixed brush position. In fact, interpoles raise sparking limit of a machine to almost the same value as heating limit. Hence, for a given output, an interpole machine can be made smaller and, therefore, cheaper than a non-interpolar machine. As interpoles carry armature current, their commutating emf is proportional to the armature current. This ensures automatic neutralization of reactance voltage which is also due to armature current. (ii) Another function of the interpoles is to neutralize the cross-magnetising effect of armature reaction. Hence, brushes are not to be shifted from the original position.

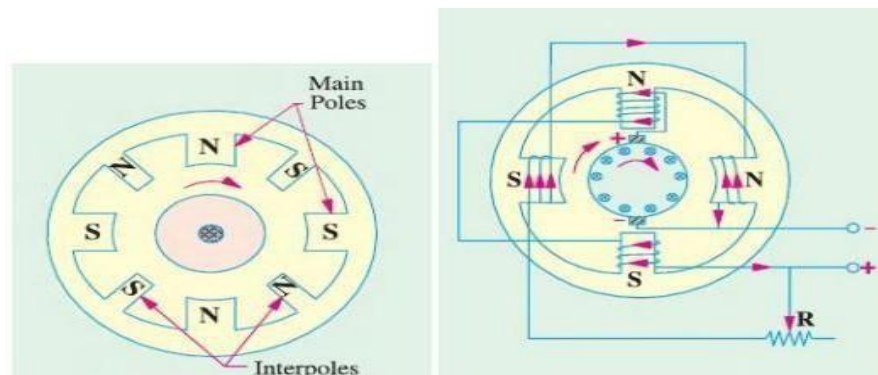

Fig: Interpoles of Compoles

OF as before, represents the mmf due to main poles. OA represents the crossmagnetising mmf due to armature. BC which represents mmf due to interpoles, is obviously in opposition to OA, hence they cancel each other out. This cancellation of crossmagnetisation is automatic and for all loads because both are produced by the same armature current. The distinction between the interpoles and compensating windings should be clearly understood. Both are connected in series and their m.m.f.s. are such as to neutralize armature reaction. But compoles additionally supply mmf for counteracting the reactance voltage induced in the coil undergoing commutation. Moreover, the action of the compoles is localized; they have negligible effect on the armature reaction occurring on the remainder of the armature periphery.

### **Types of DC Generators – Separately Excited and Self Excited**

The DC generator converts the electrical power into electrical power. The magnetic flux in a DC machine is produced by the field coils carrying current. The circulating current in the field windings produces a magnetic flux, and the phenomenon is known as Excitation. DC Generator is classified according to the methods of their field excitation.

By excitation, the DC Generators are classified as Separately excited DC Generators and Self-excited DC Generators. There is also Permanent magnet type DC generators. The self-excited DC Generators are further classified as Shunt wound DC generators; Series wound DC generators and Compound wound DC generators. The Compound Wound DC generators are further divided as long shunt wound DC generators, and short shunt wound DC generators.

The field pole of the DC generator is stationary, and the armature conductor rotates. The voltage generated in the armature conductor is of alternating nature, and this voltage is converted into the direct voltage at the brushes with the help of the commutator.

The detailed description of the various types of generators is explained below. Permanent Magnet type DC Generator

In this type of DC generator, there is no field winding is placed around the poles. The field produced by the poles of these machines remains constant. Although these machines are very compact but are used only in small sizes like dynamos in motorcycles, etc. The main disadvantage of these machines is that the flux produced by the magnets deteriorates with the passage of time which changes the characteristics of the machine.

#### **Separately Excited DC Generator**

A DC generator whose field winding or coil is energized by a separate or external DC source is called a separately excited DC Generator. The flux produced by the poles depends upon the field current with the unsaturated region of magnetic material of the poles. i.e. flux is directly proportional to the field current.

But in the saturated region, the flux remains constant.

The figure of self-excited DC Generator is shown

below.

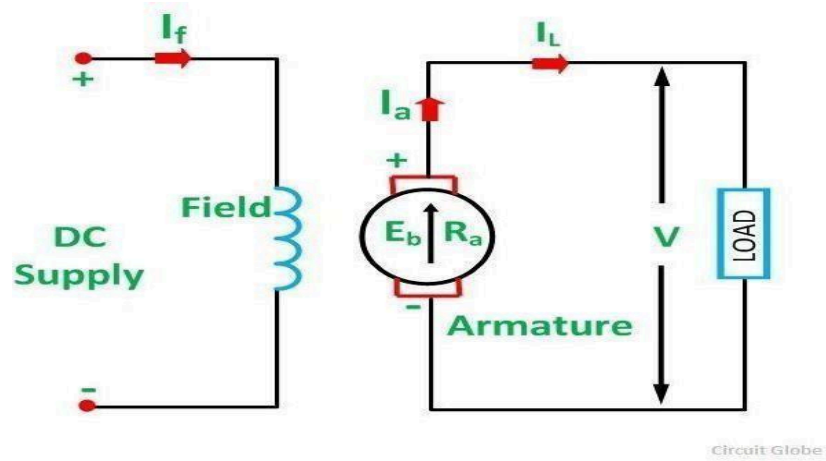

*Separately Excited DC Generator*

Here,

$I_a = I_L$  where  $I_a$  is the armature current and  $I_L$  is the line current.

Terminal voltage is given as

$$V = E_g - I_a R_a \dots \dots (1)$$

If the contact brush drop is known, then the equation (1) is written as

$$V = E_g - I_a R_a - 2v_b \dots \dots (2)$$

The power developed is given by the equation shown below.

$$\text{Power developed} = E_g I_a \dots \dots \dots (3)$$

$$\text{Power output} = V I_L = V I_a \dots \dots \dots (4)$$

Power output is given by the equation (4) shown above.

### Self Excited DC Generator

Self-excited **DC Generator** is a device, in which the current to the field winding is supplied by the generator itself. In self-excited DC generator, the field coils may be connected in parallel with the armature in the series, or it may be connected partly in series and partly in parallel with the armature windings.

**The self-excited DC Generator is further classified as**

1. Shunt Wound Generator
2. Series Wound Generator
3. Compound Wound Generator

#### 1. Shunt Wound Generator

In a **shunt wound generator**, the field winding is connected across the armature winding forming a parallel or shunt circuit. Therefore, full terminal voltage is applied across it. A very small field current  $I_{sh}$ , flows through it because this winding has many turns of fine wire having very high resistance  $R_{sh}$  of the order of 100 ohms.

The connection diagram of shunt wound generator is shown below.

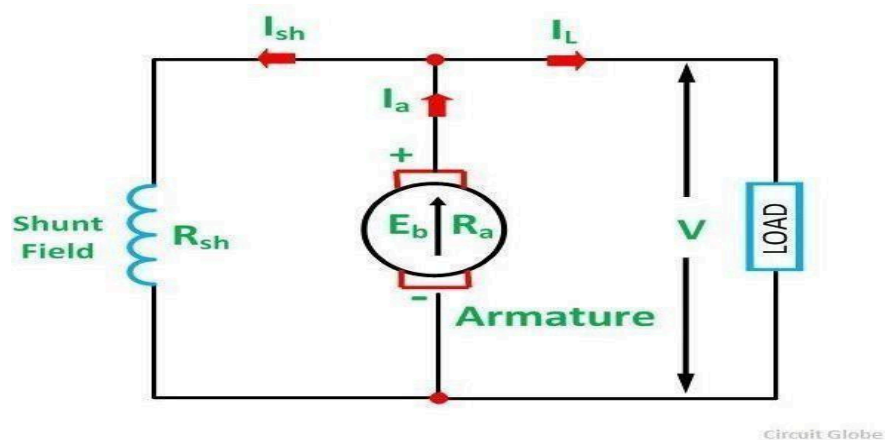

*Shunt Wound DC Generator*



Shunt field current is given as

$$I_{sh} = \frac{V}{R_{sh}}$$

Where  $R_{sh}$  is the shunt field winding resistance.

The current field  $I_{sh}$  is practically constant at all loads. Therefore, the DC shunt machine is considered to be a constant flux machine.

Armature current is given as

$$I_a = I_L + I_{sh}$$

Terminal voltage is given by the equation shown below.

$$V = E_g - I_a R_a$$

If the brush contact drop is included, the equation of the terminal voltage becomes

$$V = E_g - I_a R_a - 2v_b$$

$$\text{Power developed} = E_g I_a$$

$$\text{Power output} = V I_L$$

## 2. Series Wound Generator

A **series-wound generator** the field coils are connected in series with the armature winding. The series field winding carries the armature current. The series field winding consists of a few turns of wire of thick wire of larger cross-sectional area and having low resistance usually of the order of less than 1 ohm because the armature current has a very large value.

Its convectional diagram is shown below.

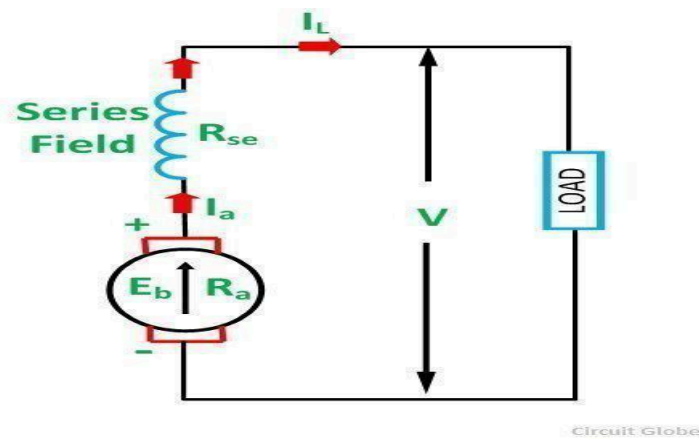

*Series Wound DC Generator*

Series field current is given as

$$I_{se} = I_L = I_a$$

$R_{se}$  is known as the series field winding resistance. Terminal voltage is given as

$$V = E_g - I_a R_a - I_{se} R_{se}$$

$$V = E_g - I_a (R_a + R_{se})$$

If the brush contact drop is included, the terminal voltage equation is written as

$$V = E_g - I_a (R_a + R_{se}) - 2V_b$$

$$\text{Power developed} = E_g I_a$$

$$\text{Power output} = V I_L = V I_a$$

The flux developed by the series field winding is directly proportional to the current flowing through it. But it is only true before magnetic saturation after the saturation flux becomes constant even if the current

flowing through it is increased.

### 3. Compound Wound Generator

In a Compound Wound Generator, there are two sets of the field winding on each pole. One of them is connected in series having few turns of thick wire, and the other is connected in parallel having many turns of fine wire with the armature windings. In other words, the generator which has both shunt and series fields is called the compound wound generators.

If the magnetic flux produced by the series winding assists the flux produced by the shunt winding, then the machine is said to be **cumulative compounded**. If the series field flux opposes the shunt field flux, then the machine is called the **differentially compounded**.

It is connected in two ways. One is a long shunt compound generator, and another is a short shunt compound generator. If the shunt field is connected in parallel with the armature alone then the machine is called the short compound generator. In long shunt compound generator, the shunt field is connected in series with the armature. The two types of generators are discussed below in details.

#### Long Shunt Compound Wound Generator

In a long shunt wound generator, the shunt field winding is parallel with both armature and series field winding. The connection diagram of long shunt wound generator is shown below.

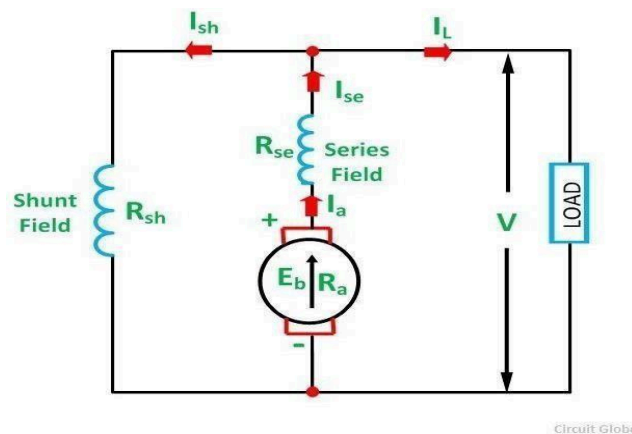

*Long Shunt Compound Wound Generator*

Shunt field current is given as

$$I_{sh} = \frac{V}{R_{sh}}$$

Series field current is given as

$$I_{se} = I_a = I_L + I_{sh}$$

Terminal voltage is given as

$$V = E_g - I_a R_a - I_{se} R_{se} = E_g - I_a (R_a + R_{se})$$

If the brush contact drop is included, the terminal voltage equation is written as

$$V = E_g - I_a (R_a + R_{se}) - 2V_b$$

$$\text{Power developed} = E_g I_a$$

$$\text{Power output} = V I_L$$

### Short Shunt Compound Wound Generator

In a Short Shunt Compound Wound Generator, the shunt field winding is connected in parallel with the armature winding only. The connection diagram of short shunt wound generator is shown below.

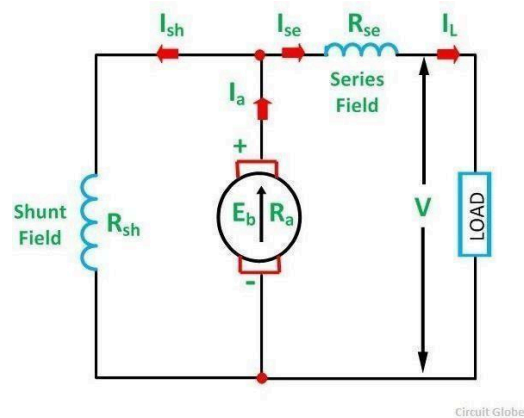

*Short Shunt Compound Wound Generator*

Series field current is given as

$$I_{se} = I_L$$

Shunt field current is given as

$$I_{sh} = \frac{V + I_L R_{se}}{R_{sh}} = \frac{E_g - I_a R_a}{R_{sh}}$$

$$I_a = I_L + I_{sh}$$

Terminal voltage is given as

$$V = E_g - I_a R_a - I_L R_{se}$$

If the brush contact drop is included, the terminal voltage equation is written as

$$V = E_g - I_a R_a - I_L R_{se} - 2V_b$$

$$\text{Power developed} = E_g I_a$$

$$\text{Power output} = V I_L$$

In this type of DC generator, the field is produced by the shunt as well as series winding. The shunt field is stronger than the series field. If the magnetic flux produced by the series winding assists the flux produced by the shunt field winding, the generator is said to be Cumulatively Compound Wound generator.

If the series field flux opposes the shunt field flux, the generator is said to be Differentially Compounded.

### **Voltage buildup in self excited Generator or Dc Shunt Generato**

A self excited DC generator supplies its own field excitation . A self excited generator shown in figure is known as a shunt generator because its field winding is connected in parallel with the armature. Thus the armature voltage supplies the field current.

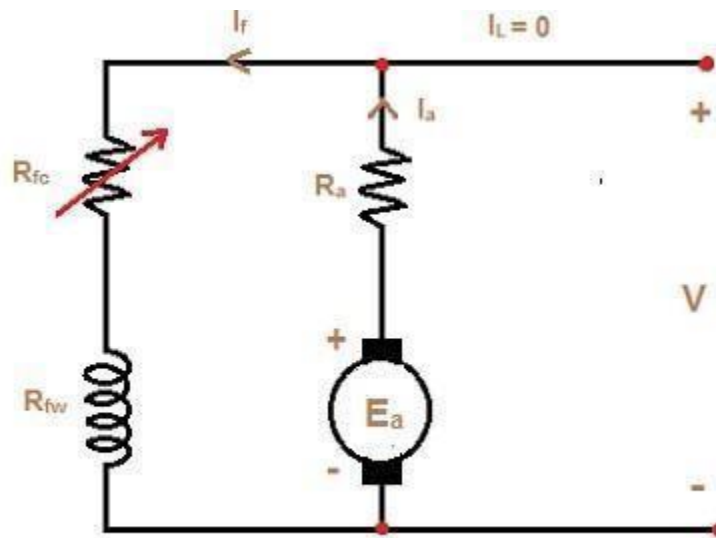

Figure - Equivalent circuit of a shunt dc generator

This generator will build up a desired terminal voltage. Assume that the generator in figure has no load connected to it and armature is driven at a certain speed by a prime mover. we shall study the condition under which the voltage buildup takes place. Due to this residual flux, a small voltage  $E_{ar}$  will be generated. It is given by

$$E_{ar} = K \phi_{res} \omega$$

This voltage is of the order of 1V or 2V . It causes a current  $I_f$  to flow in the field winding in the generator. The field current is given by

$$I_f = \frac{V}{R_f}$$

This field current produces a magneto motive force in the field winding, which increases the flux. This increase in flux increases the generated voltage  $E_a$ . The increased armature voltage  $E_a$  increases the terminal voltage  $V$ . with the increase in  $V$ , the field current  $I_f$  increases further. This in turn increases  $\Phi$  and consequently  $E_a$  increases further. The process of the voltage buildup continues. Figure shows the voltage buildup of a dc shunt generator.

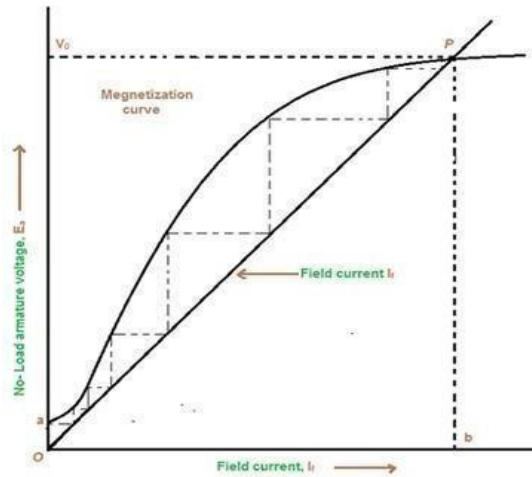

OCC Characteristics of DC generator

The effect of magnetic saturation in the pole faces limits the terminal voltage of the generator to a steady state value.

We have assumed that the generator is no load during the buildup process. The following equations describe the steady state operation.

$$I_a = I_f$$

$$V = E_a - I_a R_a = E_a - I_f R_a$$

Since the field current  $I_f$  in a shunt generator is very small, the voltage drop  $I_f R_a$  can be neglected, and  $V = E_a$

The  $E_a$  versus  $I_f$  curve is the magnetization curve shown in figure. For the field circuit  $V = I_f R_f$

The straight line given by  $V = I_f R_f$  is called the **field-resistance line**.

The field resistance line is a plot of the voltage  $I_f R_f$  across the field circuit versus the field  $I_f$ . The slope of this line is equal to the resistance of the field circuit.

The no-load terminal voltage  $V_0$  of the generator, thus, the intersection point  $P$  of the magnetization curve and the field resistance line gives the no-load terminal voltage  $V_0$  ( $OP$ ) and the corresponding field current ( $Ob$ ). Normally, in the shunt generator the voltage builds up to the value given by the point  $P$ . At this point  $E_a = I_f R_f = V_0$ .

If the field current corresponding to point  $P$  is increased further, there is no further increase in the terminal voltage.

The no-load voltage is adjusted by adding resistance in series with the shunt field. This increases the slope of this line, causing the operating point to shift to a lower voltage.

The operating point are graphical solution of two simultaneous equation namely , the magnetization curve and field resistance line . A graphical solution is preferred due to non-linear nature of magnetization curve.

Self excited generator are designed to obtain no-load voltage from 50% to 125% of the rated value while varying the added resistance in field circuit from maximum to zero value.

### Critical Field Resistance:

Figure below shows the voltage buildup in the dc shunt generator for various resistances of the field circuit.

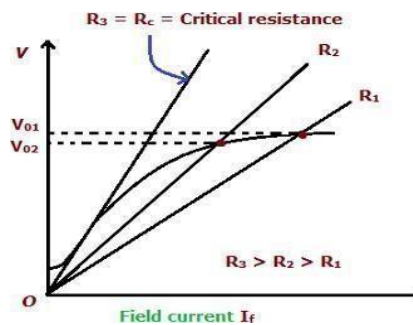

Fig: Determination of critical resistance

A decrease in the resistance of the field circuit reduces the slope of the field resistance line result in higher voltage. If the speed remains constant, an increase in the resistance of field circuit increases the slop of field resistance line, resulting in a lower voltage. If the field circuit resistance is increased to  $R_c$  which is terminal as the critical resistance of the field, the field resistance line becomes a tangent to the initial part of the magnetization curve. When the field resistance is higher than this value, the generator fails to excite.

### Critical Speed:

Figure shows the variation of no-load voltage with fixed  $R_f$  and variable speed of the armature.



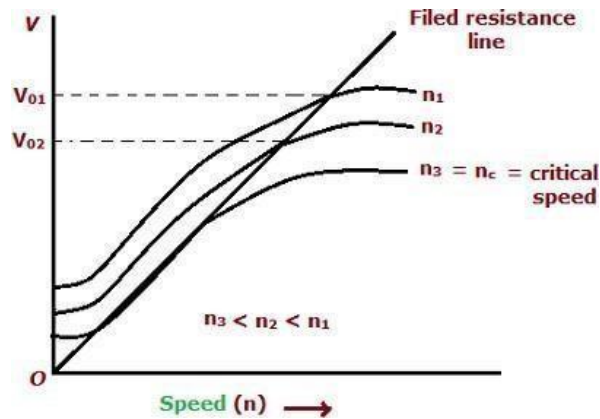

Fig: Determination of critical speed

The magnetization curve varies with the speed and its ordinate for any field current is proportional to the speed of the generator. all the points on the magnetization curve are lowered, and the point of intersection of the magnetization curve and the field resistance line moves downwards. at a particular speed, called the critical speed, the field resistance line becomes tangential to the magnetization curve. below the critical speed the voltage will not build up.

In Brief, the following condition must be satisfied for voltage buildup in a self-excited generator. There must be sufficient residual flux in the field poles.

1. the field terminal should be connected such a way that the field current increases flux in the direction of residual flux.
2. The field circuit resistance should be less than the critical field circuit resistance.

If there is a no residual flux in the field poles, Disconnected the field from the armature circuit and apply a dc voltage to the field winding. this process is called Flashing the field. It will induce some residual flux in the field poles.

### **Causes for Failure to Self Excite and Remedial Measures**

There may be one or more of the following reasons due which a self excited generator may fail to build up voltage.

#### **1. No residual magnetism**

The start of the buildup process needs some residual magnetism in the magnetic circuit of the generator. If there is little or no residual magnetism. because of inactivity or jarring in shipment, no voltage will be induced that can produce field current.

#### **2. Reversal of Field Connections**

The voltage induced owing to residual magnetism acts across the field and results in flow or current in the field coils in such a direction as to produce magnetic flux in the same direction as the residual flux.

Reversal of connections of the field winding destroys the residual magnetism which causes the generator failure to build up voltage.

### 3. In case of dc series wound generators

The resistance in the load circuit may be more than its critical resistance, which may be due to

- (i) open-circuit
- (ii) high resistance of load circuit
- (iii) faulty contact between brushes and commutator and
- (iv) commutator surface dirty or greasy.

### 4. In case of shunt wound generator

- (a) the resistance of the shunt field circuit may be greater than the critical resistance;
- (b) the resistance in the load circuit may be lower than the critical resistance;
- (c) the speed of rotation may not be equal to rated one.

### Remedy

In case the generator is started up for the first time, it may be that no voltage will be built up either because the poles have no residual magnetism or the poles have retained some residual magnetism but the field winding connections are reversed so that the magnetism developed by the field winding on start has destroyed the residual magnetism and the machine can not "build up". In both the cases, the field coils must be connected to a dc source (a storage battery) for a short while to magnetise the poles. The application of external source of direct current to the field is called flashing of the field.

## Characteristics of DC Generators

Generally, following three characteristics of DC generators are taken into considerations: (i) Open Circuit Characteristic (O.C.C.), (ii) Internal or Total Characteristic and (iii) External Characteristic. These characteristics of DC generators are explained below.

### 1. Open Circuit Characteristic (O.C.C.) ( $E_0/I_f$ )

Open circuit characteristic is also known as magnetic characteristic or no-load saturation characteristic. This characteristic shows the relation between generated emf at no load ( $E_0$ ) and the field current ( $I_f$ ) at a given fixed speed. The O.C.C. curve is just the magnetization curve and it is practically similar for all type of generators. The data for O.C.C. curve is obtained by operating the generator at no load and keeping a constant speed. Field current is gradually increased and the corresponding terminal voltage is recorded. The connection arrangement to obtain O.C.C. curve is as shown in the figure below. For shunt or series excited generators, the field winding is disconnected from the machine and connected across an external supply.

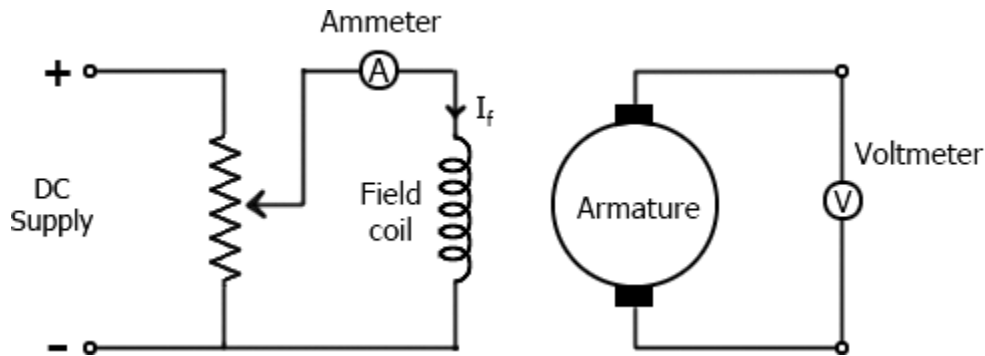
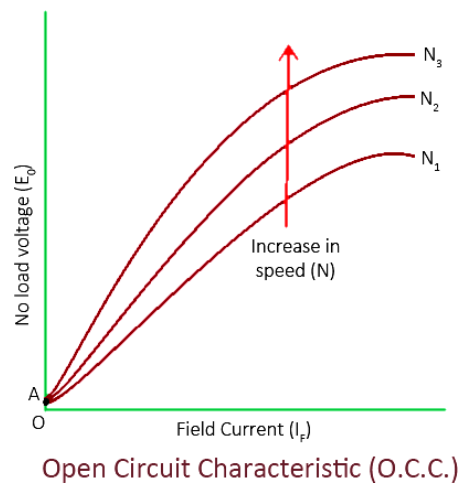

Fig: Circuit for OCC

Now, from the emf equation of dc generator, we know that  $E_g = k\phi$ . Hence, the generated emf should be directly proportional to field flux (and hence, also directly proportional to the field current). However, even when the field current is zero, some amount of emf is generated (represented by OA in the figure below). This initially induced emf is due to the fact that there exists some residual magnetism in the field poles. Due to the residual magnetism, a small initial emf is induced in the armature. This initially induced emf aids the existing residual flux, and hence, increasing the overall field flux. This consequently increases the induced emf. Thus, O.C.C. follows a straight line. However, as the flux density increases, the poles get saturated and the  $\phi$  becomes practically constant. Thus, even we increase the  $I_f$  further,  $\phi$  remains constant and hence,  $E_g$  also remains constant. Hence, the O.C.C. curve looks like the B-H characteristic.



The above figure shows a typical no-load saturation curve or open circuit characteristics for all types of DC generators.

## 2. Internal or Total Characteristic ( $E/I_a$ )

An internal characteristic curve shows the relation between the on-load generated emf ( $E_g$ ) and the armature current ( $I_a$ ). The on-load generated emf  $E_g$  is always less than  $E_0$  due to the armature reaction.  $E_g$  can be determined by subtracting the drop due to demagnetizing effect of armature reaction from no-load voltage  $E_0$ . Therefore, internal characteristic curve lies below the O.C.C. curve.

## 3. External Characteristic ( $V/I_L$ )

An external characteristic curve shows the relation between terminal voltage ( $V$ ) and the load current ( $I_L$ ). Terminal voltage  $V$  is less than the generated emf  $E_g$  due to voltage drop in the armature circuit. Therefore, external characteristic curve lies below the internal characteristic curve. External characteristics are very important to determine the suitability of a generator for a given purpose. Therefore, this type of characteristic is sometimes also called as performance characteristic or load characteristic.

Internal and external characteristic curves are shown below for each type of generator.

### Characteristics of Separately Excited DC Generator:

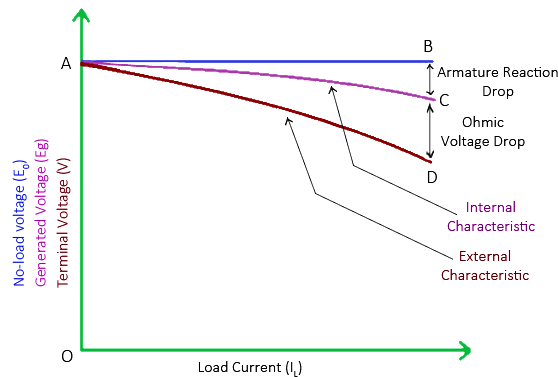

Characteristics of separately excited DC generator

If there is no armature reaction and armature voltage drop, the voltage will remain constant for any load current. Thus, the straight line AB in the above figure represents the no-load voltage vs. load current  $I_L$ . Due to the demagnetizing effect of armature reaction, the on-load generated emf is less than the no-load voltage. The curve AC represents the on-load generated emf  $E_g$  vs. load current  $I_L$ , i.e. internal characteristic (as  $I_a = I_L$  for a separately excited DC generator). Also, the terminal voltage is lesser due to ohmic drop occurring in the armature and brushes. The curve AD represents the terminal voltage vs. load current, i.e. external characteristic.

### Characteristics of DC Shunt Generator

To determine the internal and external load characteristics of a DC shunt generator the machine is allowed

to build up its voltage before applying any external load. To build up voltage of a shunt generator, the generator is driven at the rated speed by a prime mover. Initial voltage is induced due to residual magnetism in the field poles. The generator builds up its voltage as explained by the O.C.C. curve. When the generator has built up the voltage, it is gradually loaded with resistive load and readings are taken at suitable intervals. Connection arrangement is as shown in the figure below.

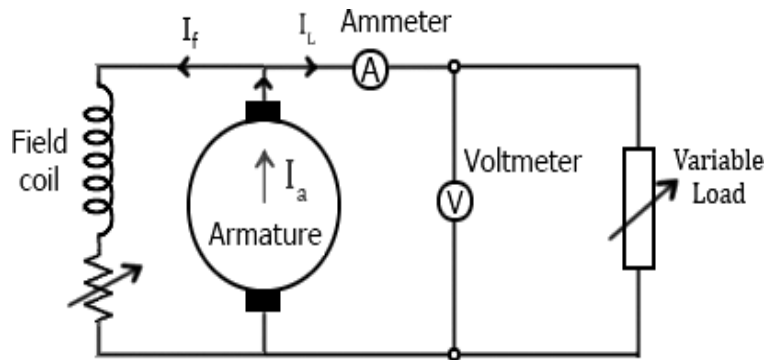
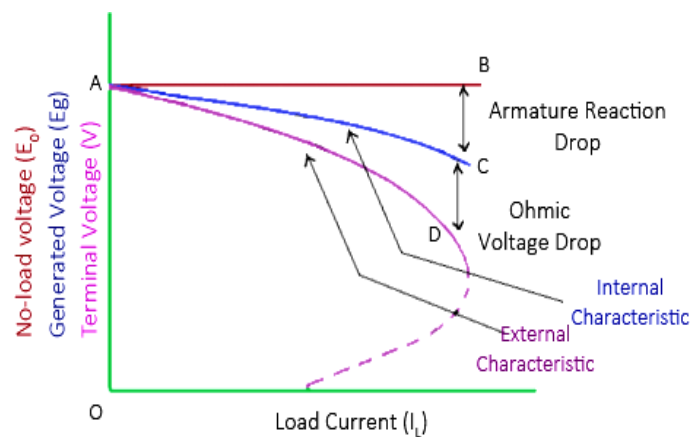

Fig: Circuit for External characteristics of shunt generator

Unlike, separately excited DC generator, here,  $I_L \neq I_a$ . For a shunt generator,  $I_a = I_L + I_f$ . Hence, the internal characteristic can be easily transmitted to  $E_g$  vs.  $I_L$  by subtracting the correct value of  $I_f$  from  $I_a$ .



Characteristics of DC shunt generator

During a normal running condition, when load resistance is decreased, the load current increases. But, as we go on decreasing the load resistance, terminal voltage also falls. So, load resistance can be decreased up to a certain limit, after which the terminal voltage drastically decreases due to excessive armature reaction at very high armature current and increased  $I^2R$  losses. Hence, beyond this limit any further decrease in load resistance results in decreasing load current. Consequently, the external characteristic

curve turns back as shown by dotted line in the above figure.

### Characteristics of DC Series Generator

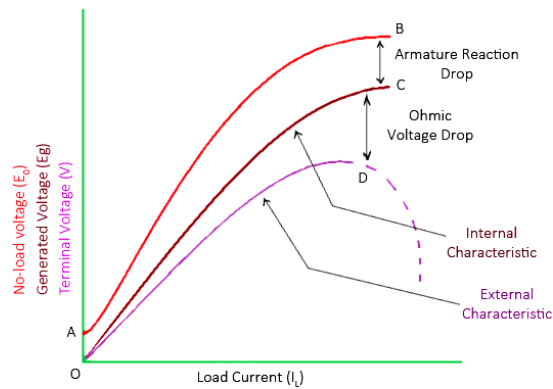

Characteristics of DC series generator

The curve AB in above figure identical to open circuit characteristic (O.C.C.) curve. This is because in DC series generators field winding is connected in series with armature and load. Hence, here load current is similar to field current (i.e.  $I_L = I_f$ ). The curve OC and OD represent internal and external characteristic respectively. In a DC series generator, terminal voltage increases with the load current. This is because, as the load current increases, field current also increases. However, beyond a certain limit, terminal voltage starts decreasing with increase in load. This is due to excessive demagnetizing effects of the armature reaction.

### Characteristics Of DC Compound Generator

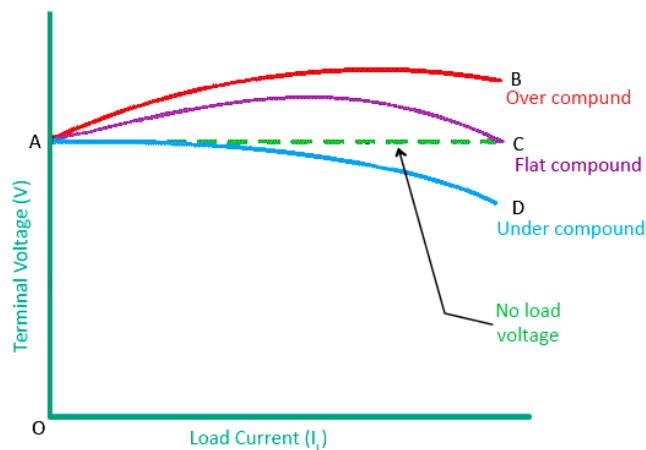

External characteristic of DC compound generator

The above figure shows the external characteristics of DC compound generators. If series winding amp-turns are adjusted so that, increase in load current causes increase in terminal voltage then the generator is called to be over compounded. The external characteristic for over compounded generator is shown by the

curve AB in above figure.

If series winding amp-turns are adjusted so that, the terminal voltage remains constant even the load current is increased, then the generator is called to be flat compounded. The external characteristic for a flat compounded generator is shown by the curve AC.

If the series winding has lesser number of turns than that would be required to be flat compounded, then the generator is called to be under compounded. The external characteristics for an under compounded generator are shown by the curve AD.

### Comparison of Lap and Wave Type Winding

Sr. No.	Lap winding	Wave winding
1.	Number of parallel paths (A) = Poles (P)	Number of parallel paths (A) = 2 (always)
2.	Number of brush sets required is equal to number of poles.	Number of brush sets required is always equal to two.
3.	Preferable for high current, low voltage capacity generators.	Preferable for high voltage, low current capacity generators.
4.	Normally used for generators of capacity more than 500 A.	Preferred for generators of capacity less than 500 A.

2)

➔ **Example** A d.c. shunt generator has shunt field winding resistance of  $100 \Omega$ . It is supplying a load of  $5 \text{ kW}$  at a voltage of  $250 \text{ V}$ . If its armature resistance is  $0.22 \Omega$  calculate the induced e.m.f. of generator.

**Solution :** Consider shunt generator as shown in the Fig. 3.9.

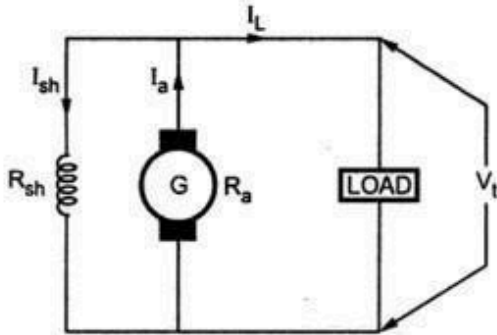

**Fig. 3.9**

$$I_a = I_L + I_{sh}$$

$$I_{sh} = \frac{V_t}{R_{sh}}$$

Now  $V_t = 250 \text{ V}$

and  $R_{sh} = 100 \Omega$

$$\therefore I_{sh} = \frac{250}{100} = 2.5 \text{ A}$$

Load power =  $5 \text{ kW}$ .

$$\therefore P = V_t \times I_L$$

$$\therefore I_L = \frac{P}{V_t} = \frac{5 \times 10^3}{250} = 20 \text{ A}$$

$$\therefore I_a = I_L + I_{sh} = 20 + 2.5 = 22.5 \text{ A}$$

Now  $E = V_t + I_a R_a$  (neglect  $V_{brush}$ )



3)

### Causes of Failure to Excite Self Excited Generator

The causes of failure, the method of detection and the corresponding remedy are given in the Table 3.1.

Sr. No.	Cause	Method of detection	Remedy
1.	Absence of residual magnetism due to ageing.	Zero reading on voltmeter after rotating armature.	Operate the generator as separately excited first and then as a self excited.
2.	Wrong field winding connections. Due to this, flux gets produced in opposite direction to residual flux. So residual flux cancels the main flux.	Voltmeter reading decreases rather than increasing as generator is started.	Interchange the field connections.
3.	Field resistance is more than the critical resistance.	Voltmeter shows zero reading.	Reduce the resistance of field circuit using proper field divertor.
4.	Generator is driven in opposite direction.	This wipes out the residual flux and fails to excite.	Drive the generator in proper direction.

4)

### Critical Field Resistance in D.C. Shunt Generator

Consider the magnetisation characteristics of a d.c. shunt generator shown in the Fig. 3.14.

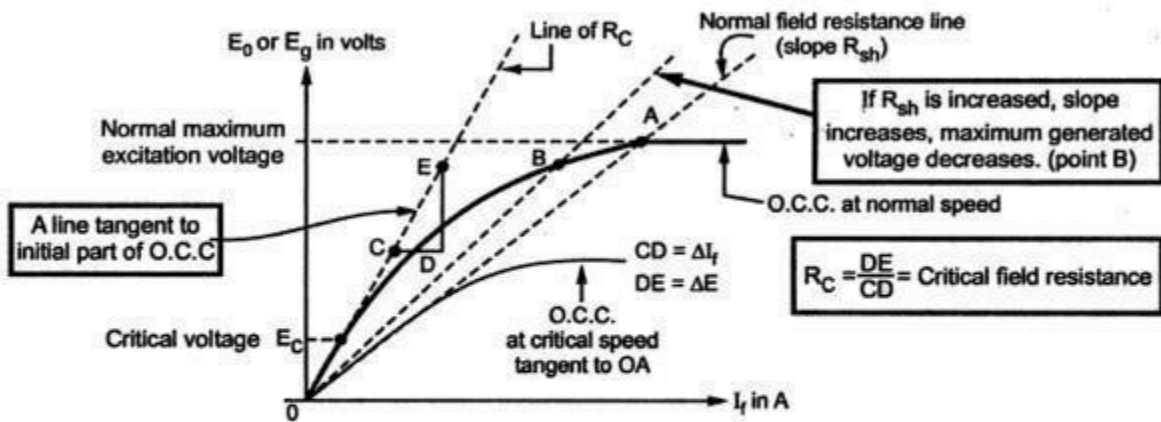

Fig. 3.14 Concept of critical resistance

The Fig. 3.14 shows that generator voltage builds in step till point A. This point is intersection of field resistance line with the open circuit characteristics (O.C.C.). The voltage corresponding to point A is the maximum voltage it can generate. If the slope of field resistance line is reduced by decreasing the field resistance, the maximum voltage generator can build will be higher than that corresponding to point A. Similarly if the slope of field resistance line is increased by increasing the field resistance, the maximum

5)

$$R_L = \frac{V_{t1}}{I_{a1}} = \frac{V_{t2}}{I_{a2}}$$

...  $I_L = I_a$  due to separately excited

$$\therefore R_L = \frac{125}{200} = \frac{V_{t2}}{I_{a2}}$$

$$\therefore V_{t2} = 0.625 I_{a2} \quad \dots(2)$$

Using in (1),  $112.5 = 0.625 I_{a2} + I_{a2} \times 0.04 + 2$

$$\therefore 0.665 I_{a2} = 110.5$$

$$\therefore I_{a2} = 166.165 \text{ A} \quad \dots\text{New current}$$

➔ **Example** A separately excited generator when running at 1200 r.p.m. supplies a current of 200 A at 125 V to a circuit of constant resistance. What will be the current when the speed drops to 1000 r.p.m. if the field current is unaltered? Armature resistance is  $0.04 \Omega$  and the total voltage drop at the brushes is 2 V. Ignore the change in armature reaction. [JNTU, May-2004 (Set-1, 4), Nov.-2008 (Set-1)]

**Solution :**  $N_1 = 1200$  r.p.m.,  $I_{a1} = 200$  A,  $V_{t1} = 125$  V,  $N_2 = 1000$  r.p.m.,  $R_a = 0.04 \Omega$

For separately excited generator with constant field current,

$$E_g \propto N$$

$$\therefore \frac{E_{g1}}{E_{g2}} = \frac{N_1}{N_2}$$

$$\begin{aligned} \text{Now } E_{g1} &= V_{t1} + I_{a1} R_a + \text{Brushdrop} = 125 + 200 \times 0.04 + 2 \\ &= 135 \text{ V} \end{aligned}$$

$$\therefore \frac{135}{E_{g2}} = \frac{1200}{1000}$$

$$\therefore E_{g2} = 112.5 \text{ V}$$

$$\text{But } E_{g2} = V_{t2} + I_{a2} R_a + \text{Brush drop} \quad \dots(1)$$

For the load of constant resistance,

Example: In a 110 V dc compound generator, the resistance of the armature, field winding, and series field winding are 0.06 Ω, 25 Ω, and 0.04 Ω respectively. The generator is required to supply 200 lamps, each of 55 W at 110 V. Calculate the generated e.m.f. and the terminal voltage.

$$E_g = V_t + I_a R_a + I_L R_{se} = 110 + 104.56 \times 0.06 + 100 \times 0.04$$

$$= 120.2736 \text{ V}$$

...Generated e.m.f.

[JNTU, May-2004 (Set-2), Nov.-2008 (Set-1)]

Solution : a) Long shunt compound

$$V_t = 110 \text{ V}$$

Each lamp  $P = 55 \text{ W} = V_t I$

$$\therefore I / \text{lamp} = \frac{55}{110} = 0.5 \text{ A}$$

$$\therefore \text{Total } I_L = 200 \text{ lamps} \times 0.5$$

$$= 100 \text{ A}$$

$$I_{sh} = \frac{V_t}{R_{sh}} = \frac{110}{25}$$

$$= 4.4 \text{ A}$$

$$\therefore I_a = I_L + I_{sh} = 104.4 \text{ A}$$

$$E_g = V_t + I_a R_a + I_a R_{se} = 110 + 104.4 [0.06 + 0.04]$$

$$= 120.44 \text{ V}$$

...Generated e.m.f.

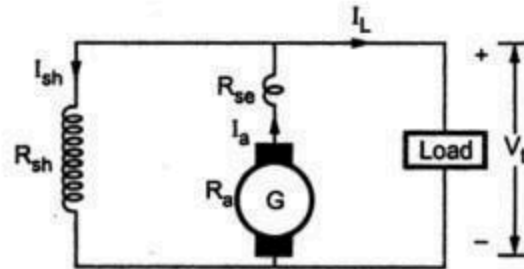

Fig. 3.29

b) Short shunt compound

The load current remains same

$$I_{sh} = \frac{V_t + I_L R_{se}}{R_{sh}}$$

$$= \frac{110 + 100 \times 0.04}{25}$$

$$= 4.56 \text{ A}$$

$$\therefore I_a = I_L + I_{sh}$$

$$= 104.56 \text{ A}$$

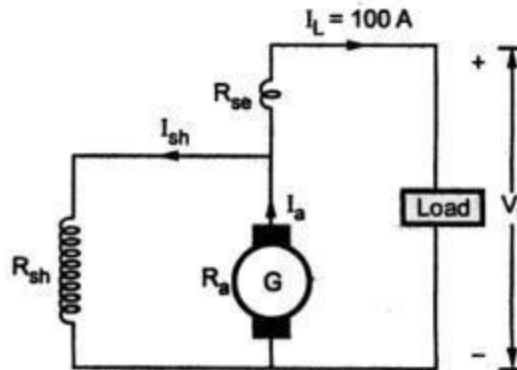

Fig. 3.30

## UNIT II

### DC MOTORS AND

#### **TESTING WORKING PRINCIPLE OF A DC MOTOR**

The DC motor is the device which converts the direct current into the mechanical work. It works on the principle of Lorentz Law, which states that “the current carrying conductor placed in a magnetic and electric field experience a force”. And that force is called the Lorentz force. The Fleming left-hand rule gives the direction of the force.

#### **Fleming Left Hand Rule**

If the thumb, middle finger and the index finger of the left hand are displaced from each other by an angle of 90°, the middle finger represents the direction of the magnetic field. The index finger represents the direction of the current, and the thumb shows the direction of forces acting on the conductor.

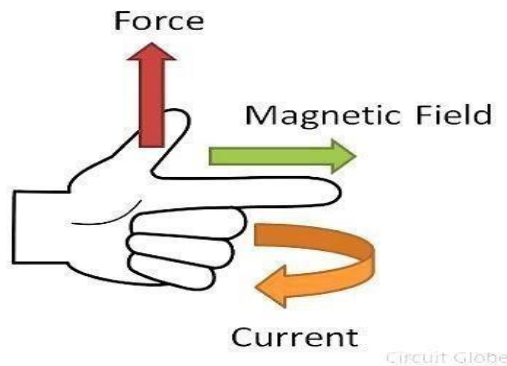

Fig: Fleming's left hand rule

The formula calculates the magnitude of the force,

$$F = BIl \quad \text{newton}$$

Before understanding the working of DC motor first, we have to know about their construction. The armature and stator are the two main parts of the DC motor. The armature is the rotating part, and the stator is their stationary part. The armature coil is connected to the DC supply.

The armature coil consists the commutators and brushes. The commutators convert the AC induces in the armature into DC and brushes transfer the current from rotating part of the motor to the stationary external load. The armature is placed between the north and south pole of the permanent or electromagnet.

For simplicity, consider that the armature has only one coil which is placed between the magnetic field shown below in the figure A. When the DC supply is given to the armature coil the current starts flowing through it. This current develops their own field around the coil. Figure B shows the field induces around

the coil.

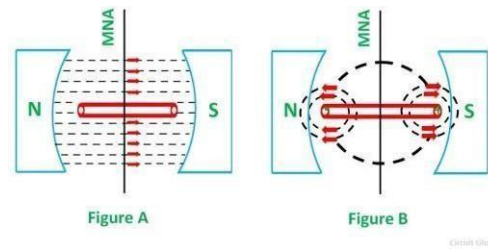

Fig: magnetic field induces around the coil.

By the interaction of the fields (produces by the coil and the magnet), resultant field develops across the conductor. The resultant field tends to regain its original position, i.e. in the axis of the main field. The field exerts the force at the ends of the conductor, and thus the coil starts rotating.

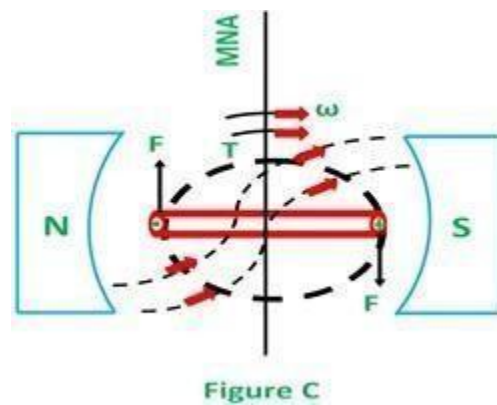

Fig: Field produced due to poles alone

Let the field produces by the main field be  $F_m$ , and this field rotates in the clockwise direction. When the current flows in the coil, they produce their own magnetic field says  $F_r$ . The field  $F_r$  tries to come in the direction of the main field. Thereby, the torque act on the armature coil.

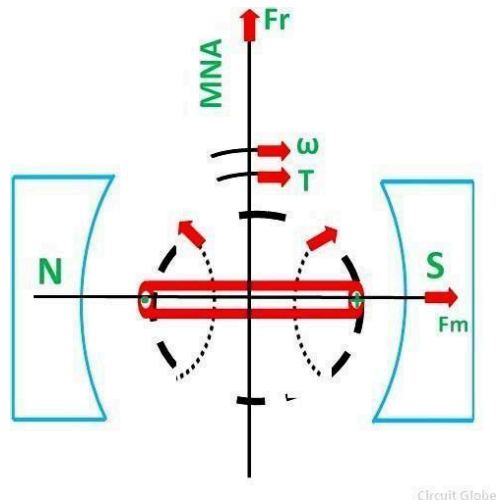

Fig: Field produced due to conductors alone

The actual DC motor consists a large number of armature coils. The speed of the motor is directly proportional to the number of coils used in the motor. These coils are kept under the impact of the magnetic field.

The one end of the conductors are kept under the influence of north pole, and the other end is kept under the influence of the South pole. The current enters into the armature coil through the north pole and move outwards through the south pole. When the coil moves from one brush to another, at the same time the polarity of the coil also changes. Thus, the direction of the force or torque acting on the coil remains same.

The torque induces in the coil become zero when the armature coil is perpendicular to the main field. The zero torque means the motor stops rotating. For solving this problem, the number of armature coil is used in the rotor. So if one of their coils is perpendicular to the field, then the other coils induce the torque. And the rotor moves continuously.

Also, for obtaining the continuous torque, the arrangement is kept in such a way that whenever the coils cut the magnetic neutral axis of the magnet the direction of current in the coils become reversed. This can be done with the help of the commutator.

### **Back Emf and its Significance in DC Motor**

When a dc voltage  $V$  is applied across the motor terminals, the armature starts rotating due to the torque developed in it.

As the armature rotates, armature conductors cut the pole magnetic field, therefore, as per law of electromagnetic induction, an emf called **back emf** is induced in them.

The back emf (also called counter emf) is given by

$$E_b = \frac{P\Phi ZN}{60A}$$

where, P=number of poles of dc

motor  $\Phi$ = flux per pole

Z=total number of armature

conductors N=armature speed

A=number of parallel paths in armature winding

As all other parameters are constant, therefore,  $E_b \propto N$

As per Lenz's law, "the induced emf always opposes the cause of its production". Here, the cause of generation of back emf is the rotation of armature. Rotation of armature is due to armature torque. Torque is due to armature current and armature current is due to supply dc voltage V. Therefore, the ultimate cause of production of  $E_b$  is the supply voltage V.

**Therefore, back emf is always directed opposite to supply voltage V.**

### **Significance of back emf in dc motor**

(1) As the back emf opposes supply voltage V, therefore, supply voltage has to force current through the armature against the back emf, to keep armature rotating. The electric work done in overcoming and causing the current to flow against the back emf is converted into mechanical energy developed in the armature.

It follows, therefore, that energy conversion in a dc motor is only possible due to the production of back emf.

Mechanical power developed in the armature =  $E_b I_a$

(2) Back emf makes dc motor a self-regulating motor i.e  $E_b$  makes motor to adjust  $I_a$  automatically as per

the load torque requirement. Lets see how.

From the motor figure,

$$I_a = \frac{V - E_b}{R_a}$$

V and Ra are fixed, therefore, armature current Ia depends on back emf, which in turn depends on speed of the motor.

(a) when the motor is running at no-load, small torque (  $T_a = K I_a$  ) is required by the motor to overcome friction and windage. Therefore, a small current is drawn by the motor armature and the back emf is almost equal to the supply voltage.

(b) If the motor is suddenly loaded, the load torque beomes greater than the armature torque and the motor starts to slow down. As motor speed decreases, back emf decreases and therefore, armature current starts increasing. With increasing Ia , armature torque increases and at some point it becomes equal to the load torque. At that moment, motor stops slowing down and keeps running at this new speed.

(c) If the load on the motor is suddenly reduced, the driving torque becomes more than the load torque and the motor starts accelerating. As the motor speed increases, back emf increases and therefore, armature current decreases. Due to this reducing armature current, armature developed torque decreases and at some point becomes equal to the load torque. That point onwards, motor will stop accelerating and will start rotating uniformly at this new slightly increased speed.

So, this shows how important is back emf in dc motor. Without back emf, the electromagnetic energy conversion would not have been possible at the first place.

### **Power Equation of a D.C. Motor**

The voltage equation of a d.c. motor is given by,

$$V = E_b + I_a R_a$$

Multiplying both sides of the above equation by Ia we get,

$$V I_a = E_b I_a + I_a^2 R_a$$

This equation is called power equation of a d.c. motor.



$V I_a$  = Net electrical power input to the armature measured in watts.

$I_a^2 R_a$  = Power loss due the resistance of the armature called armature copper loss.

So difference between  $V I_a$  and  $I_a^2 R_a$  i.e. input - losses gives the output of the armature.

So  $E_b I_a$  is called electrical equivalent of gross mechanical power developed by the armature.

This is denoted as  $P_m$ .

∴ Power input to the armature - Armature copper loss = Gross mechanical power  
developed in the armature.

### **Condition for Maximum Power**

For a motor from power equation it is known  
that,  $P_m$  = Gross mechanical power developed =  
 $E_b I_a$   
=  $V I_a - I_a^2 R_a$

For maximum  $P_m$ ,  $dP_m/dI_a = 0$

$$\therefore 0 = V - 2I_a R_a$$

$$\therefore I_a = V/2R_a \quad \text{i.e.} \quad I_a R_a =$$

$V/2$  Substituting in voltage equation,

$$V = E_b + I_a R_a = E_b + (V/2)$$

$$\therefore E_b = V/2 \quad \text{Condition for maximum power}$$

Key Point : This is practically impossible to achieve as for this, current required is much more than its normal rated value. Large heat will be produced and efficiency of motor will be less than 50 %.

### **TORQUE EQUATION OF A DC MOTOR**

When a DC machine is loaded either as a motor or as a generator, the rotor conductors carry current. These conductors lie in the magnetic field of the air gap. Thus, each conductor experiences a force. The

conductors lie near the surface of the rotor at a common radius from its centre. Hence, a torque is

produced around the circumference of the rotor, and the rotor starts rotating.

When the machine operates as a generator at a constant speed, this torque is equal and opposite to that provided by the prime mover. When the machine is operating as a motor, the torque is transferred to the shaft of the rotor and drives the mechanical load. The expression is same for the generator and motor.

When the current carrying conductor is placed in the magnetic field, a force is exerted on it which exerts turning moment or torque  $F \times r$ . This torque is produced due to the electromagnetic effect, hence is called **Electromagnetic torque**. The torque which is produced in the armature is not fully used at the shaft for doing the useful work. Some part of it is lost due to mechanical losses. The torque which is used for doing useful work is known as the shaft torque.

Since,

$$V = E_b + I_a R_a \dots \dots \dots (1)$$

Multiplying the equation (1) by  $I_a$  we get

$$VI_a = E_b I_a + I_a^2 R_a \dots \dots \dots (2)$$

Where,

$VI_a$  is the electrical power input to the armature.

$I_a^2 R_a$  is the copper loss in the armature.

We know that,

**Total electrical power supplied to the armature = Mechanical power developed by the armature + losses due to armature resistance**

Now, the mechanical power developed by the armature is  $P_m$ .

$$P_m = F_b I_a \dots \dots \dots (3)$$

Also, the mechanical power rotating armature can be given regarding torque  $T$  and speed  $n$ .

$$P_m = \omega T = 2\pi n T \dots \dots \dots (4)$$

Where  $n$  is in revolution per seconds (rps) and  $T$  is in Newton-Meter.  
Hence,

$$2\pi nT = E_b I_a \quad \text{or}$$

$$T = \frac{E_b I_a}{2\pi n}$$

But,

$$E_b = \frac{\phi ZNP}{60 A}$$

Where  $N$  is the speed in revolution per minute (rpm) and

$$n = \frac{N}{60}$$

Where,  $n$  is the speed in (rps).

Therefore,

$$E_b = \frac{\phi Z n P}{A}$$

So, the torque equation is given as

$$T = \frac{\phi Z P}{2\pi A} \cdot I_a$$

For a particular DC Motor, the number of poles (P) and the number of conductors per parallel path (Z/A) are constant.

$$T = K\phi I_a$$

Where,

$$K = \frac{ZP}{2\pi A} \quad \text{or}$$

$$T \propto \phi I_a \dots \dots (5)$$

Thus, from the above equation (5) it is clear that the torque produced in the armature is directly proportional to the flux per pole and the armature current. Moreover, the direction of electromagnetic torque developed in the armature depends upon the current in armature conductors. If either of the two is reversed the direction of torque produced is reversed and hence the direction of rotation. But when both are reversed, and direction of torque does not change.

### **Shaft Torque**

In a DC Motor whole of the electromagnetic torque (T) developed in the armature is not available on the shaft. A part of it is lost to overcome the iron and mechanical (friction and windage) losses. Therefore, shaft torque ( $T_{sh}$ ) is somewhat less than the torque developed in the armature.

**Definition:** Thus, in the case of DC motors, the actual torque available at the shaft for doing useful mechanical work is known as **Shaft Torque**. It is so called because it is available on the shaft of the motor. It is represented by the symbol  $T_{sh}$ . The output of the motor is given by the equation shown below where  $T_{sh}$  is the shaft torque in r.p.s and the N is the rotation of the motor in r.p.m. The shaft torque

is expressed as

$$\text{Output} = T_{sh} \times 2\pi N$$

$$T_{sh} = \frac{\text{Outputs in watts}}{2\pi N} \quad N - m \text{ in r.p.s}$$

$$T_{sh} = \frac{\text{Outputs in watts}}{2\pi N/60} \quad N - m \text{ in r.p.m}$$

$$T_{sh} = \frac{60 \text{Output}}{2\pi N} = 9.55 \frac{\text{Output}}{N} \quad N - m \text{ in r.p.s}$$

The difference between the armature torque and the shaft torque ( $T_a - T_{sh}$ ) is known as the lost torque and is due to the formation of the torque.

### **Brake Horse Power (B.H.P)**

In the case of the motor, the mechanical power available at the shaft is known as Brake Horse Power. If  $T_{sh}$  is the shaft torque in Newton Meter and  $N$  is the speed in r.p.m then,

$$\text{Useful output power} = \omega T_{sh} = \frac{2\pi N T_{sh}}{60} \quad \text{watts}$$

$$\text{Output in B. H. P} = \frac{2\pi N T_{sh}}{60 \times 735.5} \quad \dots \dots (1)$$

The output brake horsepower is given by the equation (1) shown above.

### **TYPES OF DC MOTOR**

A Direct Current Motor, DC is named according to the connection of the field winding with the armature. Mainly there are two types of DC Motors. First, one is Separately Excited DC Motor and Self-excited DC Motor. The self-excited motors are further classified as Shunt wound or shunt motor, Series wound or series motor and Compound wound or compound motor.

The dc motor converts the electrical power into mechanical power is known as dc motor. The



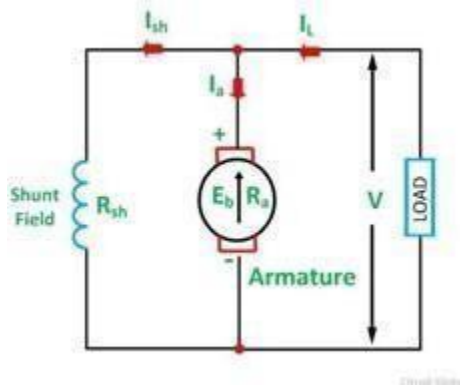

Shunt Wound DC Motor

The current, voltage and power equations for a shunt motor are written as follows.

By applying KCL at the junction A in the above figure.

The sum of the incoming currents at A = Sum of the outgoing currents at A.

$$I = I_a + I_{sh} \dots \dots \dots (1)$$

Where,

I is the input line current

Ia is the armature  
current

Ish is the shunt field current



Equation (1) is the current equation.

The voltage equations are written by using Kirchoff's voltage law (KVL) for the field winding circuit.

$$V = I_{sh}R_{sh} \dots \dots \dots (2)$$

For armature winding circuit the equation will be given as

$$V = E + I_a R_a \dots \dots \dots (3)$$

The power equation is given as

**Power input = mechanical power developed + losses in the armature + loss in the field.**

$$VI = P_m + I_a^2 R_a + I_{sh}^2 R_{sh} \dots \dots \dots (4)$$

$$VI = P_m + I_a^2 R_a + VI_{sh}$$

$$P_m = VI - VI_{sh} - I_a^2 R_a = V(I - I_{sh}) - I_a^2 R_a$$

$$P_m = VI_a - I_a^2 R_a = (V - I_a R_a)I_a$$

$$P_m = EI_a \dots \dots \dots (5)$$

Multiplying equation (3) by  $I_a$  we get the following equations.

$$VI_a = EI_a + I_a^2 R_a \dots \dots \dots (6)$$

$$VI_a = P_m + I_a^2 R_a \dots \dots \dots (7)$$

Where,

$VI_a$  is the electrical power supplied to the armature of the motor.

**Series Wound Motor**

In the series motor, the field winding is connected in series with the armature winding. The connection diagram is shown below.

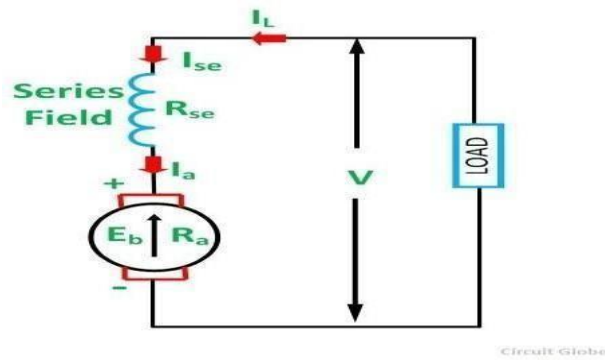

Series Wound Motor

By applying the KCL in the above figure

$$I = I_{se} = I_a$$

Where,

$I_{se}$  is the series field current

The voltage equation can be obtained by applying KVL in the above figure

$$V = E + I (R_a + R_{se}) \dots \dots \dots (8)$$

The power equation is obtained by multiplying equation (8) by I we get

$$VI = EI + I^2 (R_a + R_{se}) \dots \dots \dots (9)$$

Power input = mechanical power developed + losses in the armature + losses in the field

$$VI = P_m + I^2 R_a + I^2 R_a \dots \dots \dots (10)$$

Comparing the equation (9) and (10), we will get the equation shown below.

$$P_m = EI \dots \dots \dots (11)$$

## Compound Wound Motor

A DC Motor having both shunt and series field windings is called a **Compound Motor**. The connection diagram of the compound motor is shown below.

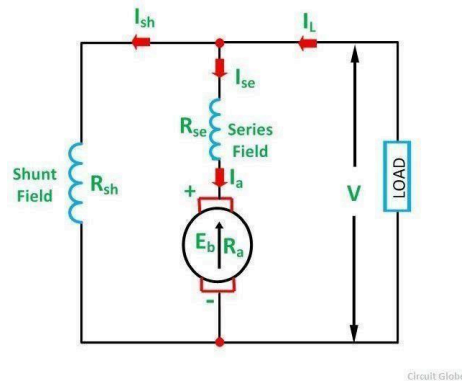

*Compound Motor*

The compound motor is further subdivided as **Cumulative Compound Motor** and **Differential Compound Motor**. In cumulative compound motor the flux produced by both the windings is in the same direction, i.e.

$$\phi_r = \phi_{sh} + \phi_{se}$$

In differential compound motor, the flux produced by the series field windings is opposite to the flux produced by the shunt field winding, i.e.

$$\phi_r = \phi_{sh} - \phi_{se}$$

The positive and negative sign indicates that direction of the flux produced in the field windings.

## CHARACTERISTICS OF DC MOTORS

Generally, three characteristic curves are considered important for DC motors which are,

- (i) Torque vs. armature current,
- (ii) Speed vs. armature current and

(iii) (iii) Speed vs. torque.

These are explained below for each type of DC motor. These characteristics are determined by keeping the following two relations in mind.

$$T_a \propto \phi \cdot I_a \text{ and } N \propto E_b / \phi$$

These above equations can be studied at - emf and torque equation of dc machine. For a DC motor, magnitude of the back emf is given by the same emf equation of a dc generator i.e.  $E_b = P\phi NZ / 60A$ . For a machine, P, Z and A are constant, therefore,  $N \propto E_b / \phi$

### **Characteristics Of DC Series Motors**

#### **Torque Vs. Armature Current ( $T_a$ - $I_a$ )**

This characteristic is also known as electrical characteristic. We know that torque is directly proportional to the product of armature current and field flux,  $T_a \propto \phi \cdot I_a$ . In DC series motors, field winding is connected in series with the armature, i.e.  $I_a = I_f$ . Therefore, before magnetic saturation of the field, flux  $\phi$  is directly proportional to  $I_a$ . Hence, before magnetic saturation  $T_a \propto I_a^2$ . Therefore, the  $T_a$ - $I_a$  curve is parabola for smaller values of  $I_a$ .

After magnetic saturation of the field poles, flux  $\phi$  is independent of armature current  $I_a$ . Therefore, the torque varies proportionally to  $I_a$  only,  $T \propto I_a$ . Therefore, after magnetic saturation,  $T_a$ - $I_a$  curve becomes a straight line.

The shaft torque ( $T_{sh}$ ) is less than armature torque ( $T_a$ ) due to stray losses. Hence, the curve  $T_{sh}$  vs  $I_a$  lies slightly lower.

In DC series motors, (prior to magnetic saturation) torque increases as the square of armature current, these motors are used where high starting torque is required.

#### **Speed Vs. Armature Current ( $N$ - $I_a$ )**

We know the relation,  $N \propto E_b / \phi$

---

For small load current (and hence for small armature current) change in back emf  $E_b$  is small and it may be neglected. Hence, for small currents speed is inversely proportional to  $\phi$ . As we know, flux is directly proportional to  $I_a$ , speed is inversely proportional to  $I_a$ . Therefore, when armature current is very small the speed becomes dangerously high. That is why a series motor should never be started without some mechanical load.

But, at heavy loads, armature current  $I_a$  is large. And hence, speed is low which results in decreased back emf  $E_b$ . Due to decreased  $E_b$ , more armature current is allowed.

### Speed Vs. Torque (N-Ta)

This characteristic is also called as mechanical characteristic. From the above two characteristics of DC series motor, it can be found that when speed is high, torque is low and vice versa.

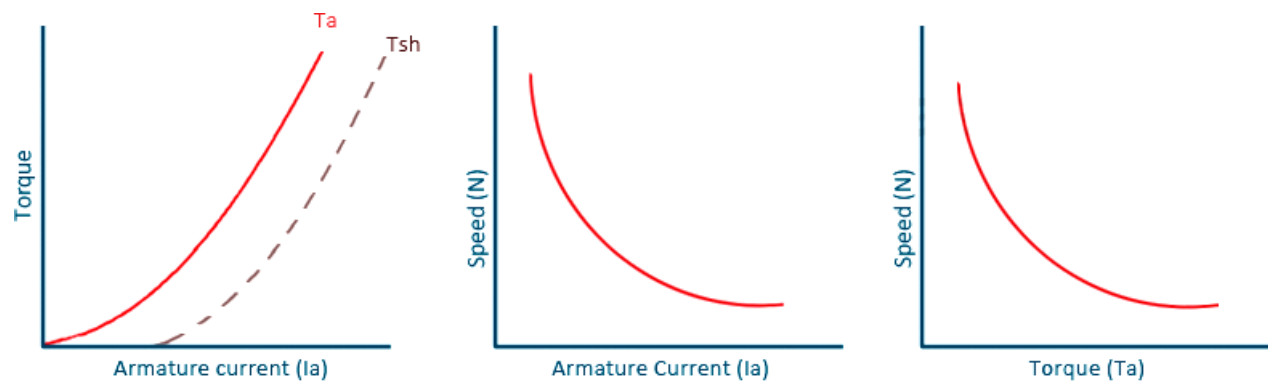

## Characteristics of DC series motor

### Characteristics Of DC Shunt Motors

#### Torque Vs. Armature Current (Ta-Ia)

In case of DC shunt motors, we can assume the field flux  $\phi$  to be constant. Though at heavy loads,  $\phi$  decreases in a small amount due to increased armature reaction. As we are neglecting the change in the flux  $\phi$ , we can say that torque is proportional to armature current. Hence, the  $T_a$ - $I_a$  characteristic for a dc shunt motor will be a straight line through the origin.

Since heavy starting load needs heavy starting current, shunt motor should never be started on a heavy load.

#### Speed Vs. Armature Current (N-Ia)

As flux  $\phi$  is assumed to be constant, we can say  $N \propto E_b$ . But, as back emf is also almost constant, the speed should remain constant. But practically,  $\phi$  as well as  $E_b$  decreases with increase in load. Back emf  $E_b$  decreases slightly more than  $\phi$ , therefore, the speed decreases slightly. Generally, the speed decreases

only by 5 to 15% of full load speed. Therefore, a shunt motor can be assumed as a constant speed motor. In speed vs. armature current characteristic in the following figure, the straight horizontal line represents the ideal characteristic and the actual characteristic is shown by the dotted line.

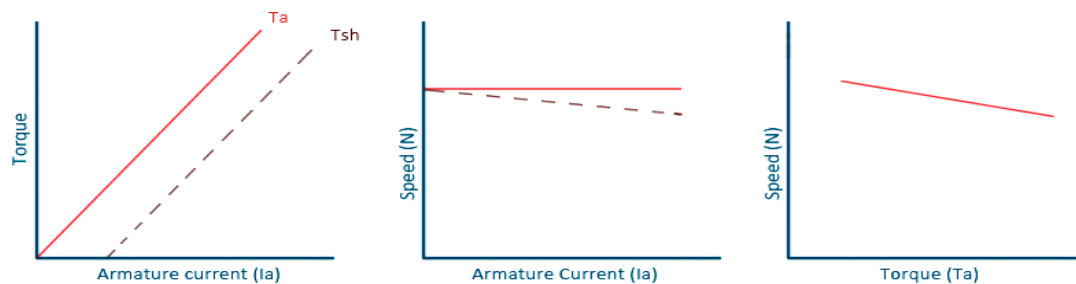

## Characteristics of DC shunt motor

### Characteristics Of DC Compound Motor

DC compound motors have both series as well as shunt winding. In a compound motor, if series and shunt windings are connected such that series flux is in direction as that of the shunt flux then the motor is said to be cumulatively compounded. And if the series flux is opposite to the direction of the shunt flux, then the motor is said to be differentially compounded. Characteristics of both these compound motors are explained below.

#### (a) Cumulative compound motor

Cumulative compound motors are used where series characteristics are required but the load is likely to be removed completely. Series winding takes care of the heavy load, whereas the shunt winding prevents the motor from running at dangerously high speed when the load is suddenly removed. These motors have generally employed a flywheel, where sudden and temporary loads are applied like in rolling mills.

#### (b) Differential compound motor

Since in differential field motors, series flux opposes shunt flux, the total flux decreases with increase in load. Due to this, the speed remains almost constant or even it may increase slightly with increase in load ( $N \propto E_b/\phi$ ). Differential compound motors are not commonly used, but they find limited applications in experimental and research work.

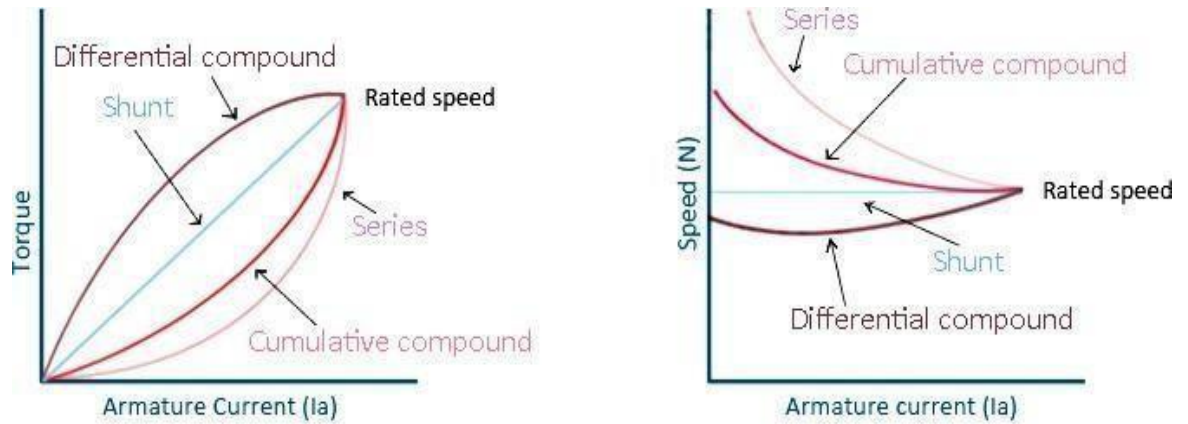

## Characteristics of DC compound motor

### SPEED CONTROL OF DC MOTOR:

The dc motor converts the mechanical power into dc electrical power. One of the most important features of the dc motor is that their speed can easily be control according to the requirement by using simple methods. Such type of control is impossible in an AC motor.

The concept of the speed regulation is different from the speed control. In speed regulation, the speed of the motor changes naturally whereas in dc motor the speed of the motor changes manually by the operator or by some automatic control device. The speed of the DC Motor is given by the relation shown below.

The equation (1) that the speed is dependent upon the supply voltage V, the armature circuit resistance  $R_a$  and the field flux  $\phi$ , which is produced by the field current.

$$N = \frac{V - I_a R_a}{k\phi} \dots \dots \dots (1)$$

For controlling the speed of DC Motor, the variation in voltage, armature resistance and field flux is taken into consideration. There are three general methods of speed control of a DC Motor. They are as follows.

1. Variation of resistance in the armature circuit. This method is called Armature Resistance or Rheostatic control.
2. Variation in field flux. This method is known as Field Flux Control.
3. Variation in applied voltage. This method is also known as Armature Voltage Control.

The detailed discussion of the various method of controlling the speed is given below.

## Armature Resistance Control of DC Motor

### Shunt Motor

The connection diagram of a shunt motor of the armature resistance control method is shown below. In this method, a variable resistor  $R_e$  is put in the armature circuit. The variation in the variable resistance does not effect the flux as the field is directly connected to the supply mains.

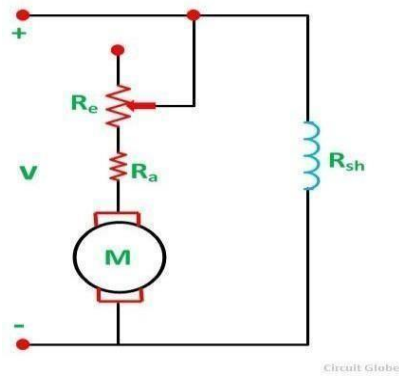

Fig: Connection diagram of a shunt motor of the armature resistance control method

The **speed current characteristic** of the shunt motor is shown below.

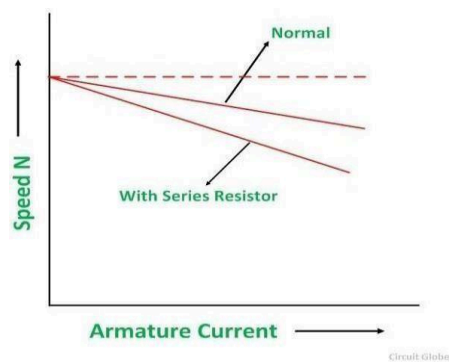

Fig: Speed current characteristic of the shunt motor

### Series Motor:

Now, let us consider a connection diagram of speed control of the DC Series motor by the armature resistance control method.



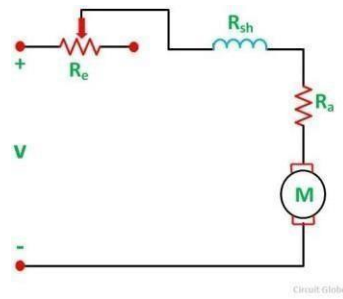

Fig: Diagram of speed control of the DC Series motor

By varying the armature circuit resistance, the current and flux both are affected. The voltage drop in the variable resistance reduces the applied voltage to the armature, and as a result, the speed of the motor is reduced.

The **speed–current characteristic** of a series motor is shown in the figure below.

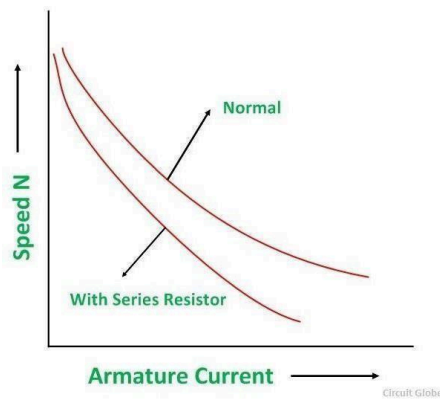

Fig: Speed–current characteristic of a series motor

When the value of variable resistance  $R_e$  is increased, the motor runs at a lower speed. Since the variable resistance carries full armature current, it must be designed to carry continuously the full armature current.

## Disadvantages of Armature Resistance Control Method

- A large amount of power is wasted in the external resistance  $R_e$ .
- Armature resistance control is restricted to keep the speed below the normal speed of the motor and increase in the speed above normal level is not possible by this method.
- For a given value of variable resistance, the speed reduction is not constant but varies with the motor load.
- This speed control method is used only for small motors.

## Field Flux Control Method of DC Motor

Flux is produced by the field current. Thus, the speed control by this method is achieved by control of the field current.

### Shunt Motor

In a Shunt Motor, the variable resistor  $R_c$  is connected in series with the shunt field windings as shown in the figure below. This resistor  $R_c$  is known as a **Shunt Field Regulator**.

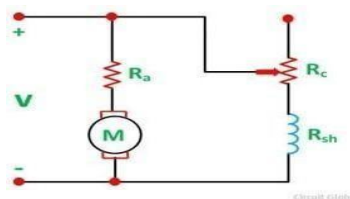

Fig: Shunt Field

Regulator The shunt field current is given by the equation shown below.

$$I_{sh} = \frac{V}{R_{sh} + R_c}$$

The connection of  $R_c$  in the field reduces the field current, and hence the flux is also reduced. This reduction in flux increases the speed, and thus, the motor runs at speed higher than the normal speed. Therefore, this method is used to give motor speed above normal or to correct the fall of speed because of the load.

The **speed-torque curve** for shunt motor is shown below.

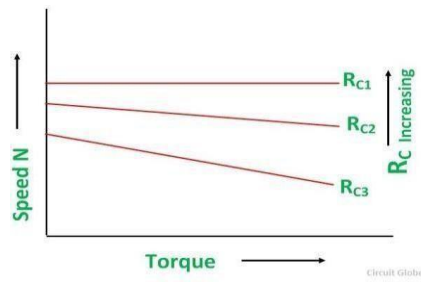

Fig: speed-torque curve for shunt motor

## Series Motor

In a series motor, the variation in field current is done by any one method, i.e. either by a diverter or by a tapped field control.

### **By Using a Diverter:**

A variable resistance  $R_d$  is connected in parallel with the series field windings as shown in the figure below.

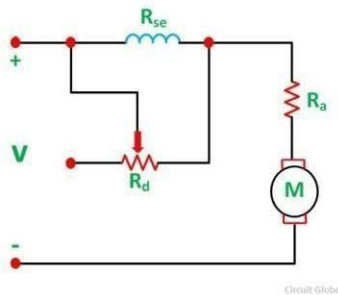

Fig: Diverter is connected in parallel with the series field windings

The parallel resistor is called a Diverter. A portion of the main current is diverted through a variable resistance  $R_d$ . Thus, the function of a diverter is to reduce the current flowing through the field winding. The reduction in field current reduces the amount of flux and as a result the speed of the motor increases.

### **Tapped Field Control:**

The second method used in a series motor for the variation in field current is by tapped field control. The connection diagram is shown below.

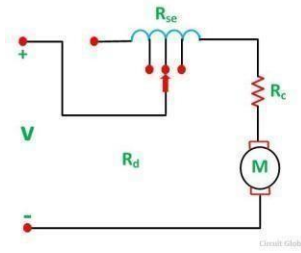

Fig: Tapped Field Control

Here the ampere turns are varied by varying the number of field turns. This type of arrangement is used in an electric traction system. The speed of the motor is controlled by the variation of the field flux. The speed-torque characteristic of a series motor is shown below.

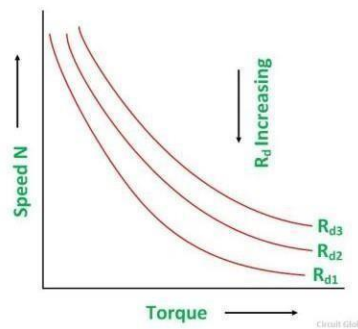

Fig: Speed-torque characteristic

### **Advantages of Field Flux Control**

The following are the advantages of the field flux control method.

- This method is easy and convenient.
- As the shunt field is very small, the power loss in the shunt field is also small.

The flux cannot usually be increased beyond its normal values because of the saturation of the iron. Therefore, speed control by flux is limited to the weakening of the field, which gives an increase in speed. This method is applicable over only to a limited range because if the field is weakened too much, there is a loss of stability.

### **Armature Voltage Control of DC Motor**

In armature voltage control method the speed control is achieved by varying the applied voltage in the

armature winding of the motor. This speed control method is also known as **Ward Leonard Method**, which is discussed in detail under the topic Ward Leonard Method or Armature Voltage Control.

### Ward Leonard Method Of Speed Control Or Armature Voltage Control

**Ward Leonard Method** of speed control is achieved by varying the applied voltage to the armature. This method was introduced in 1891. The connection diagram of the Ward Leonard method of speed control of a DC shunt motor is shown in the figure below.

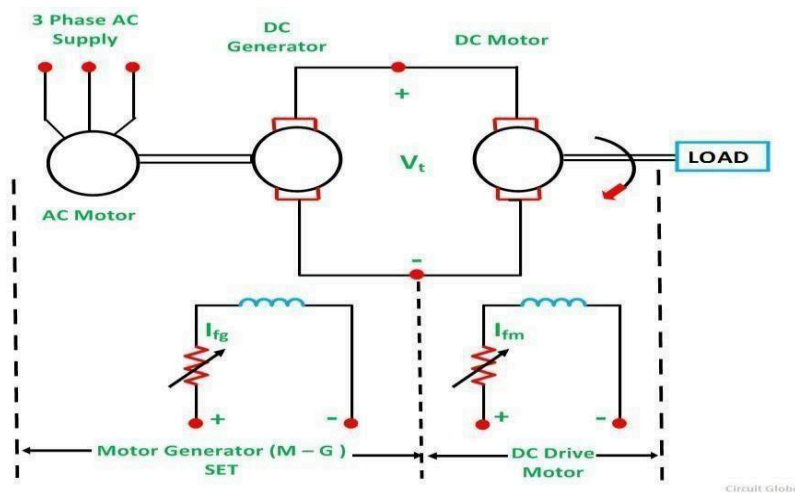

In the above system, M is the main DC motor whose speed is to be controlled, and G is a separately excited DC generator. The generator G is driven by a 3 phase driving motor which may be an induction motor or a synchronous motor. The combination of AC driving motor and the DC generator is called the **Motor-Generator (M-G) set**.

The voltage of the generator is changed by changing the generator field current. This voltage when directly applied to the armature of the main DC motor, the speed of the motor M changes. The motor field current  $I_{fm}$  is kept constant so that the motor field flux  $\phi_m$  also remains constant. While the speed of the motor is controlled, the motor armature current  $I_a$  is kept equal to its rated value.

The generated field current  $I_{fg}$  is varied such that the armature voltage  $V_t$  changes from zero to its rated value. The speed will change from zero to the base speed. Since the speed control is carried out with the

rated current  $I_a$  and with the constant motor field flux, a constant torque is directly proportional to the armature current, and field flux up to rated speed is obtained. The product of torque and speed is known as power, and it is proportional to speed. Thus, with the increase in power, speed increases automatically.

The **Torque and Power Characteristic** is shown in the figure below.

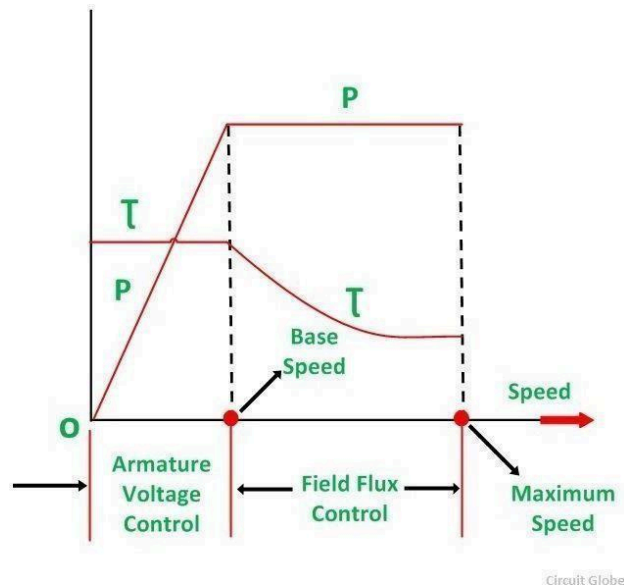

Hence, with the armature voltage control method, constant torque and variable power drive is obtained from speed below the base speed. The Field flux control method is used when the speed is above the base speed. In this mode of operation, the armature current is maintained constant at its rated value, and the generator voltage  $V_t$  is kept constant.

The motor field current is decreased and as a result, the motor field flux also decreases. This means that the field is weakened to obtain the higher speed. Since  $V_t I_a$  and  $E I_a$  remain constant, the electromagnetic torque is directly proportional to the field flux  $\phi_m$  and the armature current  $I_a$ . Thus, if the field flux of the motor is decreased the torque decreases.

Therefore, the torque decreases, as the speed increases. Thus, in the field control mode, constant power and variable torque are obtained for speeds above the base speed. When the speed control over a wide range is required, a combination of armature voltage control and field flux control is used. This combination permits the ratio of maximum to minimum speed available speeds to be 20 to 40. For closed loop control, this range can be extended up to 200.

The driving motor can be an induction or synchronous motor. An induction motor operates at a lagging power factor. The synchronous motor may be operated at a leading power factor by over-excitation of its field. Leading reactive power is generated by over excited synchronous motor. It compensates for the lagging reactive power taken by other inductive loads. Thus, the power factor is improved.

A Slip ring induction motor is used as p prime mover when the load is heavy and intermittent. A flywheel is mounted on the shaft of the motor. This scheme is known as Ward Leonard-Ilgener scheme. It prevents

heavy fluctuations in supply current.

When the Synchronous motor is acting as a driving motor, the fluctuations cannot be reduced by mounting a flywheel on its shaft, because the synchronous motor always operates at a constant speed. In another form of Ward Leonard drive, non-electrical prime movers can also be used to drive the DC generator.

For example – In DC electric locomotive, DC generator is driven by a diesel engine or a gas turbine and ship propulsion drives. In this system, Regenerative braking is not possible because energy cannot flow in the reverse direction in the prime mover.

### **Advantages of Ward Leonard Drives**

The main advantages of the Ward Leonard drive are as follows:-

- Smooth speed control of DC motor over a wide range in both the direction is possible.
- It has an inherent braking capacity.
- The lagging reactive volt-amperes are compensated by using an overexcited synchronous motor as the drive and thus, the overall power factor improves.
- When the load is intermittent as in rolling mills, the drive motor is an induction motor with a flywheel mounted to smooth out the intermittent loading to a low value.

### **Drawbacks of Classical Ward Leonard System**

The Ward Leonard system with rotating Motor Generator sets has following drawbacks.

- The Initial cost of the system is high as there is a motor generator set installed, of the same rating as that of the main DC motor.
- Larger size and weight.
- Requires large floor area
- Costly foundation
- Maintenance of the system is frequent.
- Higher losses.
- Lower efficiency.
- The drive produces more noise.

□

### **Applications of Ward Leonard Drives**

The Ward Leonard drives are used where a smooth speed control of the DC motors over a wide range in both the directions is required. Some of the examples are as follows:-

- Rolling mills
- Elevators



- Cranes
- Paper mills
- Diesel-electric locomotives
- Mine hoists

### **Solid State Control or Static Ward Leonard System**

Now a days Static Ward Leonard system is mostly used. In this system, the rotating motor-generator (M-G) set is replaced by a solid state converter to control the speed of the DC motor. Controlled Rectifiers and choppers are used as a converter.

In the case of an AC supply, controlled rectifiers are used to convert fixed AC supply voltage into a variable AC supply voltage. In the case of DC supply, choppers are used to obtain variable DC voltage from the fixed DC voltage.

### **STARTING OF DC MOTORS**

A **starter** is a device to start and accelerate a motor. A controller is a device to start the motor, control and reverse the speed of the DC motor and stop the motor. While starting the DC motor, it draws the heavy current which damages the motor. The starter reduces the heavy current and protects the system from damage.

### **Need of Starters for DC Motors**

The dc motor has no back EMF. At the starting of the motor, the armature current is controlled by the resistance of the circuit. The resistance of the armature is low, and when the full voltage is applied at the standstill condition of the motor, the armature current becomes very high which damage the parts of the motor.

Because of the high armature current, the additional resistance is placed in the armature circuit at starting. The starting resistance of the machine is cut out of the circuit when the machine gains it speeds. The armature current of a motor is given by

$$I_a = \frac{V - E}{R_a} \dots \dots \dots (1)$$

Thus,  $I_a$  depends upon  $E$  and  $R_a$ , if  $V$  is kept constant. When the motor is first switched ON, the armature is stationary. Hence, the back EMF  $E_b$  is also zero. The initial starting armature current

$I_{as}$  is given by the equation shown below.

$$I_{as} = \frac{V - 0}{R_a} = \frac{V}{R_a} \dots \dots \dots (2)$$

Since, the armature resistance of a motor is very small, generally less than one ohm. Therefore, the starting armature current  $I_{as}$  would be very large. **For example** – if a motor with the armature resistance of 0.5 ohms is connected directly to a 230 V supply, then by putting the values in the equation (2) we will get.

$$I_{as} = \frac{V}{R_a} = \frac{230}{0.5} = 460 \quad \text{Ampere}$$

This large current would damage the brushes, commutator and windings.

As the motor speed increases, the back EMF increases and the difference ( $V - E$ ) goes on decreasing. This results in a gradual decrease of armature current until the motor attains its stable speed and the corresponding back EMF. Under this condition, the armature current reaches its desired value. Thus, it is found that the back EMF helps the armature resistance in limiting the current through the armature.

Since at the time of starting the DC Motor, the starting current is very large. At the time of starting of all DC Motors, except for very small motors, an extra resistance must be connected in series with the armature. This extra resistance is added so that a safe value of the motor is maintained and to limit the starting current until the motor has attained its stable speed.

The series resistance is divided into sections which are cut out one by one, as the speed of the motor rises and the back EMF builds up. The extra resistance is cut out when the speed of the motor builds up to its normal value.

---

## 3 POINT STARTER

**3 Point Starter** is a device whose main function is starting and maintaining the speed of the DC shunt motor. The 3 point starter connects the resistance in series with the circuit which reduces the high starting current and hence protects the machines from damage. Mainly there are three main points or terminals in 3 point starter of DC motor. They are as follows

- **L** is known as Line terminal, which is connected to the positive supply.
- **A** is known as the armature terminal and is connected to the armature windings.
- **F** or **Z** is known as the field terminal and is connected to the field terminal windings.

The **3 Point DC Shunt Motor Starter** is shown in the figure below

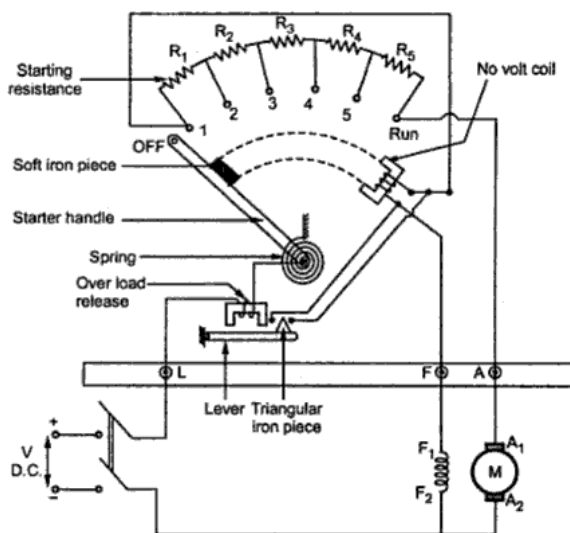

**3 point Starter**

It consists of a graded resistance  $R$  to limit the starting current. The handle  $H$  is kept in the **OFF** position by a spring  $S$ . The handle  $H$  is manually moved, for starting the motor and when it makes contact with resistance stud one the motor is said to be in the **START** position. In this initial start position, the field winding of the motor receives the full supply voltage, and the armature current is limited to a certain safe value by the resistance ( $R = R_1 + R_2 + R_3 + R_4$ ).

### **Working of 3 Point Starter**

The starter handle is now moved from stud to stud, and this builds up the speed of the motor until it reaches the **RUN** position. The Studs are the contact point of the resistance. In the RUN position, three main points are considered. They are as follows.

- The motor attains the full speed.
- The supply is direct across both the windings of the motor.
- The resistance R is completely cut out.

The handle H is held in RUN position by an electromagnet energised by a **no volt trip coil (NVC)**. This no volt trip coil is connected in series with the field winding of the motor. In the event of switching OFF, or when the supply voltage falls below a predetermined value, or the complete failure of supply while the motor is running, NVC is energised. The handle is released and pulled back to the OFF position by the action of the spring. The current to the motor is cut off, and the motor is not restarted without a resistance R in the armature circuit. The no voltage coil also provides protection against an open circuit in the field windings.

The No Voltage Coil (NVC) is called **NO-VOLT** or **UNDERVOLTAGE** protection of the motor. Without this protection, the supply voltage might be restored with the handle in the RUN position. The full line voltage is directly applied to the armature. As a result, a large amount of current is generated.

The other protective device incorporated in the starter is the overload protection. The **Over Load Trip Coil (OLC)** and the **No Voltage Coil (NVC)** provide the overload protection of the motor. The overload coil is made up of a small electromagnet, which carries the armature current. The magnetic pull of the Overload trip coil is insufficient to attract the strip P, for the normal values of the armature current

When the motor is overloaded, that is the armature current exceeds the normal rated value, P is attracted by the electromagnet of the OLC and closes the contact aa thus, the No Voltage Coil is short-circuited, shown in the figure of 3 Point Starter. As a result, the handle H is released, which returns to the OFF position, and the motor supply is cut off.

To stop the motor, the starter handle should never be pulled back as this would result in burning the starter contacts. Thus, to stop the motor, the main switch of the motor should be opened.

## **Drawbacks of a 3 Point Starter**

The following drawbacks of a 3 point starter are as follows:-

- The 3 point starter suffers from a serious drawback for motors with a large variation of speed by adjustment of the field rheostat.
- To increase the speed of the motor, the field resistance should be increased. Therefore, the current through the shunt field is reduced.
- The field current may become very low because of the addition of high resistance to obtain a high speed.
- A very low field current will make the holding electromagnet too weak to overcome the force exerted by the spring.
- The holding magnet may release the arm of the starter during the normal operation of the motor and thus, disconnect the motor from the line. This is not a desirable action.

Hence, to overcome this difficulty, the 4 Point Starter is used.

## UNIT-III

### TESTING OF D.C. MACHINES

#### LOSSES IN DC MACHINE

The losses that occur in a DC Machine is divided into five basic categories. The various losses are Electrical or Copper losses ( $I^2R$  losses), Core losses or Iron losses, Brush losses, Mechanical losses, Stray load losses. These losses are explained below in detail.

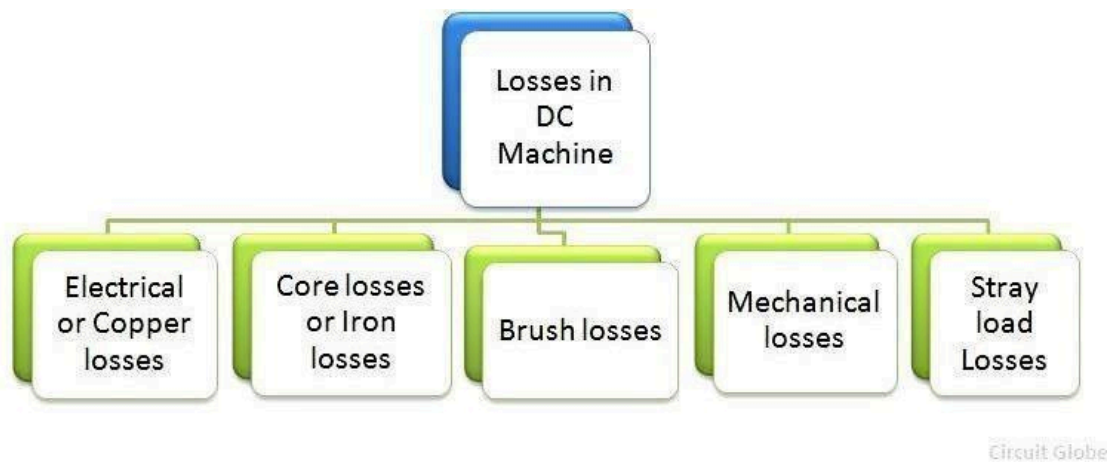

Fig: Classification of losses in DC machines

#### **Electrical or Copper Losses in dc machine**

These losses are also known as Winding losses as the copper loss occurs because of the resistance of the windings. The ohmic loss is produced by the current flowing in the windings. The windings that are present in addition to the armature windings are the field windings, interpoles and compensating windings.

Armature copper losses =  $I^2 R_a$  where  $I$  is armature current, and  $R_a$  is the armature resistance. These losses are about 30 percent of the total full load losses.

In shunt machine, the Copper loss in the shunt field is  $I_{sh}^2 R_{sh}$ , where  $I_{sh}$  is the current in the shunt

field, and  $R_{sh}$  is the resistance of the shunt field windings. The shunt regulating resistance is included in  $R_{sh}$ .

In a series machine, the copper loss in the series windings is  $I_{se}^2 R_{se}$ , where,  $I_{se}$  is the current through the series field windings, and  $R_{se}$  is the resistance of the series field windings.

In a Compound machine, both the shunt and the series field losses occur. These losses are almost 20 percent of the full load losses.

Copper losses in the interpole windings are written as  $I_a^2 R_i$  where  $R_i$  is the resistance of the interpole windings.

Copper loss in the compensating windings if any is  $I_a^2 R_c$  where  $R_c$  is the resistance of compensating windings.

### **Magnetic Losses or Core Losses or Iron Losses in dc machine**

The core losses are the hysteresis and eddy current losses. These losses are considered almost constant as the machines are usually operated at constant flux density and constant speed. These losses are about 20 percent of the full load losses.

### **Brush Losses in dc machine**

Brush losses are the losses taking place between the commutator and the carbon brushes. It is the power loss at the brush contact point. The brush drop depends upon the brush contact voltage drop and the armature current  $I_a$ . It is given by the equation shown below.

The voltage drop occurring over a large range of armature currents, across a set of brushes is approximately constant. If the value of brush voltage drop is not given then it is usually assumed to be about 2 volts. Thus, the brush drop loss is taken as  $2I_a$ .

### **Mechanical Losses in dc machine**

The losses that take place because of the mechanical effects of the machines are known as

mechanical losses. Mechanical losses are divided into bearing friction loss and windage loss. The losses occurring in the moving parts of the machine and the air present in the machine is known as Windage losses. These losses are very small.

### Stray Losses in dc machine

These losses are the miscellaneous type of losses. The following factors are considered in stray load losses.

- The distortion of flux because of armature reaction.
- Short circuit currents in the coil, undergoing commutation.

These losses are very difficult to determine. Therefore, it is necessary to assign the reasonable value of the stray loss. For most machines, stray losses are taken by convention to be one percent of the full load output power.

### EFFICIENCY OF DC GENERATOR

**Efficiency** is simply defined as the ratio of output power to the input power. Let  $R$  = total resistance of the armature circuit (including the brush contact resistance, at series winding resistance, inter-pole winding resistance and compensating winding resistance). The efficiency of DC generator is explained below in the line diagram.

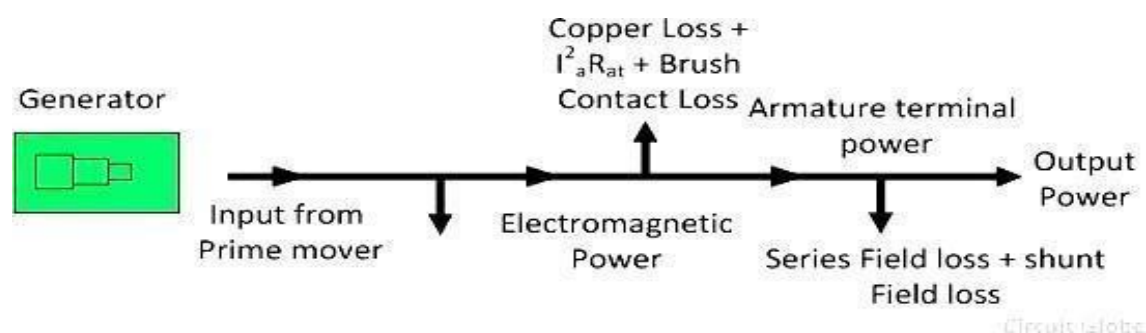

Fig: Power flow diagram

- $I$  is the output current
- $I_{sh}$  is the current through the shunt field



- $I_a$  is the armature current =  $I + I_{sh}$
- $V$  is the terminal voltage.

Total copper loss in the armature circuit =  $I_a^2 R_{at}$

Power loss in the shunt circuit =  $V_{sh}$  (this includes the loss in the shunt regulating resistance).

Mechanical losses = friction loss of bearings + friction loss at a commutator + windage loss.

Core losses = hysteresis loss + eddy current loss

Stray loss = mechanical loss + core loss

The sum of the shunt field copper loss and stray losses may be considered as a combined fixed (constant) loss that does not vary with the load current  $I$ .

Therefore, the constant losses (in shunt and compound generators) = stray loss + shunt field copper losses.

$$\text{Total Losses} = I_a^2 R_{at} + p_k + V_{BD} I_a$$

### **SWINBURNE'S TEST**

Swinburne's Test is an indirect method of testing of DC machines. In this method the losses are measured separately and the efficiency at any desired load is predetermined. Machines are tested for finding out

losses, efficiency and temperature rise. For small machines direct loading test is performed. For large shunt machines, indirect methods are used like Swinburne's or Hopkinson's test.

The machine is running as a motor at rated voltage and speed. The connection diagram for DC shunt machine is shown in the figure below.

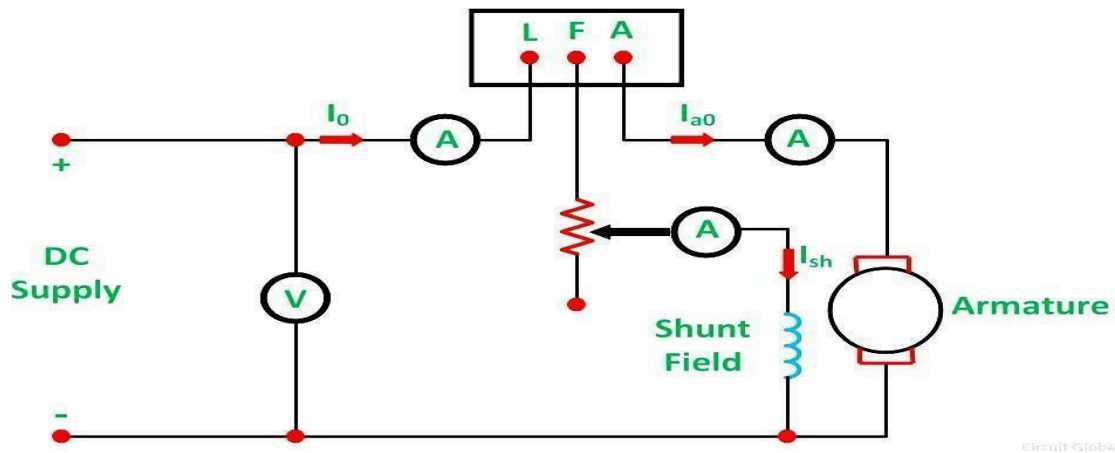

Fig: Swinburne's Test

Let

$V$  be the supply voltage

$I_0$  is the no-load current

$I_{sh}$  is the shunt field current

Therefore, no load armature current is given by the equation shown below.

$$I_{a0} = I_0 - I_{sh}$$

No-load input =  $VI_0$

The no-load power input to the machine supplies the following, as given below.

- Iron loss in the core
- Friction losses in the bearings and commutators.
- Windage loss
- Armature copper loss at no load.

When the machine is loaded, the temperature of the armature winding and the field winding increases due to  $I^2R$  losses. For calculating  $I^2R$  losses hot resistances should be used. A stationary measurement of

resistances at room temperature of  $t$  degree Celsius is made by passing current through the armature and then field from a low voltage DC supply. Then the heated resistance, allowing a temperature rise of  $50^{\circ}\text{C}$  is found. The equations are as follows:-

$$R_{t_1} = R_0 (1 + \alpha_0 t_1)$$

$$R_{t_1+50^{\circ}} = R_0 [1 + \alpha_0 (t_1 + 50^{\circ})]$$

Where,  $\alpha_0$  is the temperature coefficient of resistance at  $0^{\circ}\text{C}$

Therefore,

$$R_{t_1+50^{\circ}} = R_{t_1} \frac{1 + \alpha_0 (t_1 + 50^{\circ})}{1 + \alpha_0 t_1}$$

Stray loss = iron loss + friction loss + windage loss = input at no load – field copper loss – no load armature copper loss

$$= VI_0 - p_f - p_{a0} = p_s$$

Also, constant losses

$$p_c = \text{no load input} - \text{no load armature copper loss}$$

$$p_c = p_s + p_f$$

If the constant losses of the machine are known, its efficiency at any other load can be determined as follows.

Let  $I$  be the load current at which efficiency is required. Efficiency when the machine is running as a Motor.

$$\text{Motor input} = VI$$

$$\text{Armature copper loss} = I_a^2 R_a = (I - I_{sh})^2 R_a$$

$$\text{Constant losses} = p_c$$

Therefore, total losses is given as

$$\text{Total losses} = (I - I_{sh})^2 R_a + p_c$$

The efficiency of the motor is given below.

$$\eta_m = \frac{\text{input} - \text{losses}}{\text{input}}$$
$$\eta_m = \frac{VI - (I - I_{sh})^2 R_a + p_c}{VI}$$

Efficiency when the machine is running as a Generator.

$$\text{Generator output} = VI$$

$$\text{Armature current} = I_a = I + I_{sh}$$

$$\text{Armature copper loss} = (I + I_{sh})^2 R_a$$

$$\text{Constant losses} = p_c$$

Therefore, total losses is given as

$$\text{Total losses} = (I + I_{sh})^2 R_a + p_c$$

The efficiency of the generator is given below.

$$\eta_g = \frac{\text{output}}{\text{output} + \text{losses}}$$
$$\eta_g = \frac{VI}{VI + (I + I_{sh})^2 R_a + p_c}$$

### **Advantages of Swinburne's Test:**

The main advantages of the Swinburne's test are as follows:-

- The power required to test a large machine is small. Thus, this method is an economical and convenient method of testing of DC machines.
- As the constant loss is known the efficiency can be predetermined at any load.

### **Disadvantages of Swinburne's Test:**

- Change in iron loss is not considered at full load from no load. Due to armature reaction flux is distorted at full load and, as a result, iron loss is increased.
- As the Swinburne's test is performed at no load. Commutation on full load cannot be determined whether it is satisfactory or not and whether the temperature rise is within the specified limits or not.

### **Limitations of Swinburne's Test:**

- Machines having a constant flux are only eligible for Swinburne's test. For examples – shunt machines and level compound generators.
- Series machines cannot run on light loads, and the value of speed and flux varies greatly. Thus, the Swinburne's Test are not applicable for series machines

□

### **BRAKE TEST ON DC SHUNT MOTOR:**

Brake test is a method of finding efficiency of dc motors. We took dc shunt motor as running machine. Brake test also called as direct loading test of testing the motor because loading will be applied directly on shaft of the motor by means of a belt and pulley arrangement.

### **Test Requirements:**

1. DC shunt motor
2. Water-cooled pulley
3. Spring balance

### **Procedure of Brake Test on DC Shunt Motor:**

1. By adjusting the handle of the pulley take different readings of the spring balance.
2. The tension in the belt can be adjusted using the handle. The tension in kg can be obtained from the spring balance readings.
3. Adjusting the load step by step till full load, number of readings can be obtained. By increasing the load is slowly, adjust to get rated load current.
4. The power developed gets wasted against the friction between belt and shaft. Due to the braking action of belt the test is called brake test.

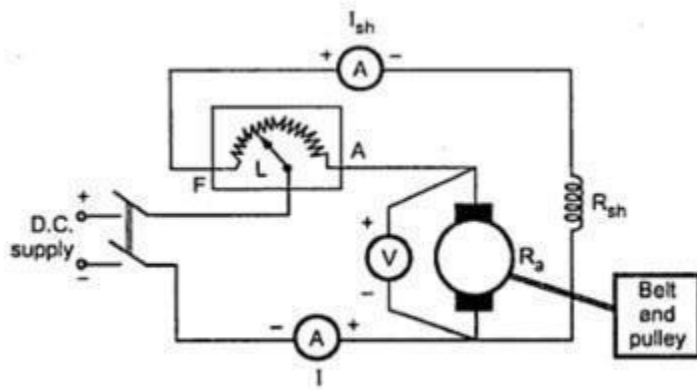

(a) Experimental setup

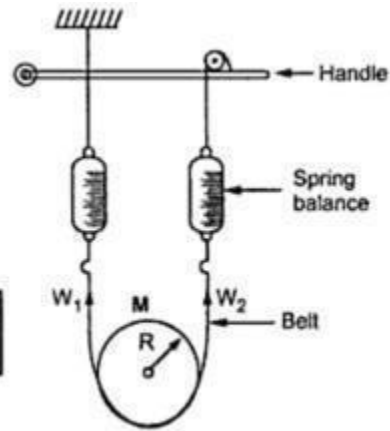

(b) Belt and pulley arrangement

5. The speed can be measured by tachometer. Thus all the motor characteristics can be plotted.

### Calculation of Brake Test on DC Shunt Motor

Let  $R$  (or)  $r$  = Radius of pulley in

meters  $N$  = Speed in R.P.M.

$W_1$  = spring balance reading on tight side in kg

$W_2$  = spring balance reading on slack side in

kg

So, net pull on the belt due to friction at the pulley is the difference between the two spring balance readings.

$$\text{Net pull on the rope} = (W - S) \text{ kg} = (W - S) \times 9.81 \text{ newtons} \quad (1)$$

As radius  $R$  and speed  $N$  are known, the shaft torque developed can be obtained

$$\text{as, } T_{sh} = \text{Net pull} \times R = (W - S) \times 9.81 \times R \quad (2)$$

Now let,  $V$  = Voltage applied in volts

$I$  = Total line current drawn in amps.

As we know  $V$  and  $I$  are input parameters of dc motors in brake test. Then,

$$P_{in} = V.I \text{ Watts} \quad (3)$$

We have output and input. Then why late go and find the efficiency of dc shunt motor.

Efficiency ( $\eta$ ) = Output/Input [No units]

From equation (2) & (3)

$$\text{Output power} = \frac{2\pi N T_{sh}}{60} = \frac{2\pi N \times (W - S) \times 9.81 \times r}{60} \quad \text{watts}$$

### **Advantages of Brake Test on DC Shunt Motor:**

1. Actual efficiency of the motor under working conditions can be found out.
2. Brake test is simple and easy to perform.
3. It is not only for dc shunt motor, also can be performed on any type of D.C. motor.

### **Disadvantages of Brake Test on DC Shunt Motor:**

1. In brake test due the belt friction lot of heat will be generated and hence there is large dissipation of energy.
2. Cooling arrangement is necessary to minimize the heat. Mostly in our laboratories we use water as cooling liquid.
3. Convenient only for small rated machines due to limitations regarding heat dissipation arrangements.
4. Power developed gets wasted hence brake test method is little expensive.
5. The efficiency observed is on lower side.

### **HOPKINSON'S TEST**

Hopkinson's Test is also known as Regenerative Test, Back to Back test and Heat Run Test. In Hopkinson Test, two identical shunt machines are required which are coupled both mechanically and electrically in parallel. One is acting as a motor and another one as a generator. The input to the motor is given by the supply mains.

The mechanical output of motor drives the generator, and the electrical output of the generator is used in supplying the input to the motor. Thus, the output of each machine acts as an input to the other machine. When both the machines are running on the full load, the supply input is equal to the total losses of the machines. Hence, the power input from the supply is very small.

The **Circuit Diagram of the Hopkinson's Test** is shown in the figure below.

Supply is given and with the help of a starter, the machine M starts and work as a motor. The switch S is kept open. The field current of M is adjusted with the help of rheostat field  $R_M$ , which enables the motor to run at rated speed. Machine G acts as a generator. Since the generator is mechanically coupled to the motor, it runs at the rated speed of the motor.

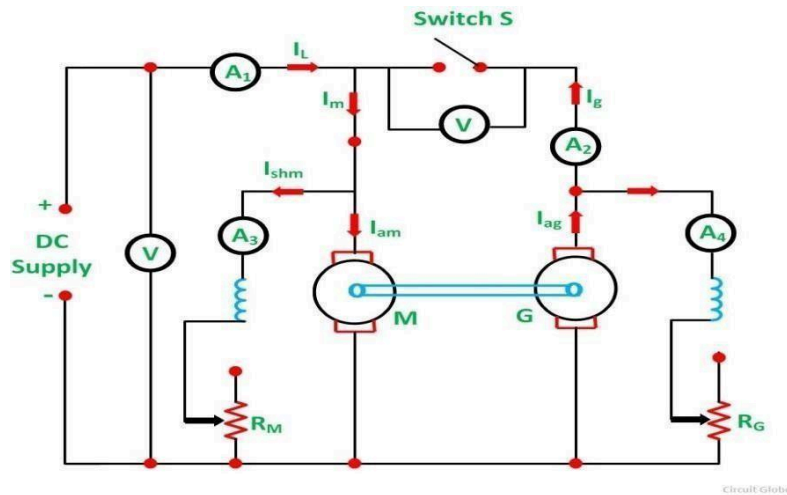

Fig: Hopkinson's Test

The excitation of the generator G is so adjusted with the help of its field rheostat  $R_G$  that the voltage across the armature of the generator is slightly higher than the supply voltage. In actual the terminal voltage of the generator is kept 1 or 2 volts higher than the supply voltage.

When the voltage of the generator is equal and of the same polarity as the of the busbar supply voltage, the main switch S is closed, and the generator is connected to the busbars. Thus, both the machines are now in parallel across the supply. Under this condition, when the machines are running parallel, the generator are said to float. This means that the generator is neither taking any current nor giving any current to the supply.

Now with the help of a field rheostat, any required load can be thrown on the machines by adjusting the excitation of the machines with the help of field rheostats.

Let,

- $V$  be the supply voltage
- $I_L$  is the line current
- $I_m$  is the input current to the motor
- $I_g$  is the input current to the generator
- $I_{am}$  is the motor armature current



- $I_{shm}$  is the

tor shunt field current

motor •  $R_a$  is the armature resistance of each

machine shunt

field current

- $R_{shm}$  is the motor shunt field resistance

- $I_{shg}$  is the

- $R_{shg}$  is the generator shunt field resistance

generator •  $E_m$  is the motor induced voltage or back emf

- $E_g$  is the generator induced voltage

$$E_g = V + I_{ag} R_a$$

$$E_m = V - I_{am} R_a$$

Therefore,

$$E_g > E_m$$

But,

$$E_g \propto \phi_g N \quad \text{and} \quad E_m \propto \phi_m N$$

Hence,

$$\phi_g > \phi_m$$

Since the field flux is directly proportional to the field current.

$$\phi \propto I_f$$

$$I_{shg} > I_{shm}$$

Thus, the excitation of the generator shall always be greater than that of the motor.

Calculation of the Efficiency of the Machine by Hopkinson's Test

□ Power input from the supply =  $V I_L$  = total losses of both the machines

□ Armature copper loss of the motor =  $I_{am}^2 R_a$

□ Field copper loss of the motor =  $I_{shm}^2 R_{shm}$

□ Armature copper loss of the generator =

$I_{ag}^2 R_a$  □ Field copper loss of the generator =  $I_{shg}^2 R_{shg}$

$I^2$

$R$

The constant losses  $P_c$  like iron, friction and windage losses are assumed to be equal and is written as given below.

Constant losses of both the machines = Power drawn from the supply – Armature and shunt copper losses of both the machines.

$$P_C = V I_L - (I_{am}^2 R_a + I_{shm}^2 R_{shm} + I_{ag}^2 R_a + I_{shg}^2 R_{shg})$$

Assuming that the constant losses known as stray losses are divided equally between the two machines.

Total stray loss per machine =  $\frac{1}{2} P_c$

### Efficiency of the Generator

- Output =  $V I_{ag}$
- Constant losses for generator is given as  
 $\frac{P_c}{2}$  □ Armature copper loss =  $I_{ag}^2 R_a$
- Field copper loss =  $I_{shg}^2 R_{shg}$

The Efficiency of the generator is given by the equation shown below

$$\eta_g = \frac{\text{Output}}{\text{Output} + \text{Losses}}$$
$$\eta_g = \frac{V I_{ag}}{V I_{ag} + I_{ag}^2 R_a + I_{shg}^2 R_{shg} + \frac{1}{2} P_c}$$

### Efficiency of the Motor

$$\text{Input} = V I_m = V(I_{am} + I_{shm})$$

- Constant losses of the motor is given as  
 $\frac{P_c}{2}$  □ Armature copper loss =  $I_{am}^2 R_a$
- Field copper loss =  $I_{shm}^2 R_{shm}$

The **Efficiency** of the motor is given by the equation shown below

$$\eta_m = \frac{\text{Output}}{\text{Input}} = \frac{\text{Input} - \text{losses}}{\text{Input}}$$
$$\eta_m = \frac{V(I_{am} + I_{shm}) - \left(\frac{P_c}{2} + I_{am}^2 R_a + I_{shm}^2 R_{shm}\right)}{V(I_{am} + I_{shm})}$$

### Advantages of Hopkinson's Test

The main advantages of using Hopkinson's test are as follows:-

□ This method is very economical.

- The temperature rise and the commutation conditions can be checked under rated load conditions.
- Stray losses are considered, as both the machines are operated under rated load conditions.
- Large machines can be tested at rated load without consuming much power from the supply.
- Efficiency at different loads can be determined.

### Disadvantage of Hopkinson's Test

The main disadvantage of this method is the necessity of two practically identical machines for performing the Hopkinson's test. Hence, this test is suitable for large DC machines.

### FIELD'S TEST:

This is one of the methods of testing the D.C. series motors. Unlike shunt motors, the series motor cannot be tested by the methods which are available for shunt motors as it is impossible to run the motor on no-load. It may run at dangerously high speed on no load. In case of small series motors brake test may be employed.

The series motors are usually tested in pairs. The field test is applied to two similar series motors which are coupled mechanically. The connection diagram for the test is shown in the Fig. 1.

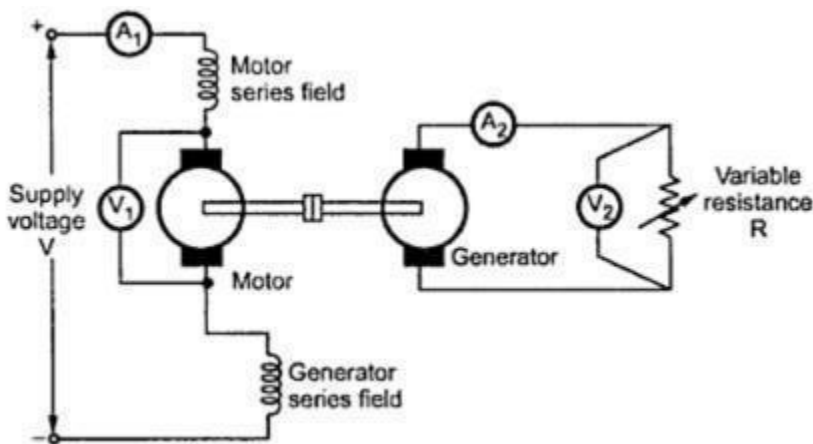

**Fig. 1** Field test

As shown in the Fig. 1 one machine is made to run as a motor while the other as a generator which is separately excited. The fields of the two machines are connected in series so that both the machines are equally excited. This will make iron losses same for the two machines. The two machines are running at the same speed. The generator output is given to the variable resistance  $R$ .

The resistance  $R$  is changed until the current taken by motor reaches full load value. This will be indicated by ammeter  $A_1$ . The other readings of different meters are then recorded.

Let  $V$  = Supply voltage

$I_1$  = Current taken by motor

$I_2$  = Load current

$V_2$  = Terminal p.d. of generator

$R_a, R_{se}$  = Armature and series field resistance of each machine

Power taken from supply =  $V I_1$

Output obtained from generator =  $V_2 I_2$

Total losses in both the machines,  $W_T = V I_1 - V_2 I_2$

Armature copper and field losses,  $W_{CU} = (R_a + 2 R_{se}) I_1^2 + I_2^2 R_a$

Total stray losses =  $W_T - W_{CU}$

$$\text{Stray losses per machine, } W_s = \frac{W_T - W_{CU}}{2}$$

Since the two machines are equally excited and are running at same speed the stray losses are equally divided.

### For Motor;

Input to motor =  $V_1 I_1$

Total losses = Armature Cu loss + Field Cu loss + Stray loss

$$= I_1^2 (R_a + R_{se}) + W_s$$

Output of motor = Input - Total losses =  $V_1 I_1 - [I_1^2 (R_a + R_{se}) + W_s]$

$$\text{Efficiency of motor, } \eta_m = \frac{\text{Output}}{\text{Input}}$$

$$\eta_m = \frac{V_1 I_1 - [I_1^2 (R_a + R_{se}) + W_s]}{V_1 I_1}$$

### For Generator:

Efficiency of generator is of little importance because it is running under conditions of separate

excitation. Still it can be found as follows.

$$\text{Output of generator} = V_2 I_2$$

$$\text{Field Cu loss} = I_1^2 R_{sc}$$

$$\text{Armature Cu loss} = I_a^2 R_a$$

$$\text{Total losses} = \text{Armature Cu loss} + \text{Field Cu loss} + \text{Stray loss}$$

$$= I_a^2 R_a + I_1^2 R_{sc} + W_s$$

$$\text{Input to generator} = \text{Output} + \text{Total losses} = V_2 I_2 + [I_a^2 R_a + I_1^2 R_{sc} + W_s]$$

$$\text{Efficiency of generator, } \eta_g = \frac{\text{Output}}{\text{Input}}$$

$$\therefore \eta_g = \frac{V_2 I_2}{V_2 I_2 + [I_a^2 R_a + I_1^2 R_{sc} + W_s]}$$

The important point to be noted is that this is not regenerative method though the two machines are mechanically coupled because the generator output is not fed back to the motor as in case of Hopkinson's test but it is wasted in load resistance.

### **RETARDATION TEST OR RUNNING DOWN TEST**

This method is generally employed to shunt generators and shunt motors. From this method we can get stray losses. Thus if armature and shunt copper losses at any given load current are known then efficiency of a machine can be easily estimated.

The machine whose test is to be taken is run at a speed which is slightly above its normal speed. The supply to the motor is cut off while the field is kept excited. The armature consequently slows down and its kinetic energy is used in supplying the rotational or stray losses which includes iron, friction and winding loss.

If  $I$  is the amount of inertia of the armature and  $\omega$  is the angular velocity.

$$\text{Kinetic energy of armature} = 0.5 I \omega^2$$

$\therefore$  Rotational losses,  $W = \text{Rate of change of kinetic energy}$



$$= \frac{d}{dt} \left( \frac{1}{2} I \omega^2 \right) = I \omega \frac{d\omega}{dt}$$

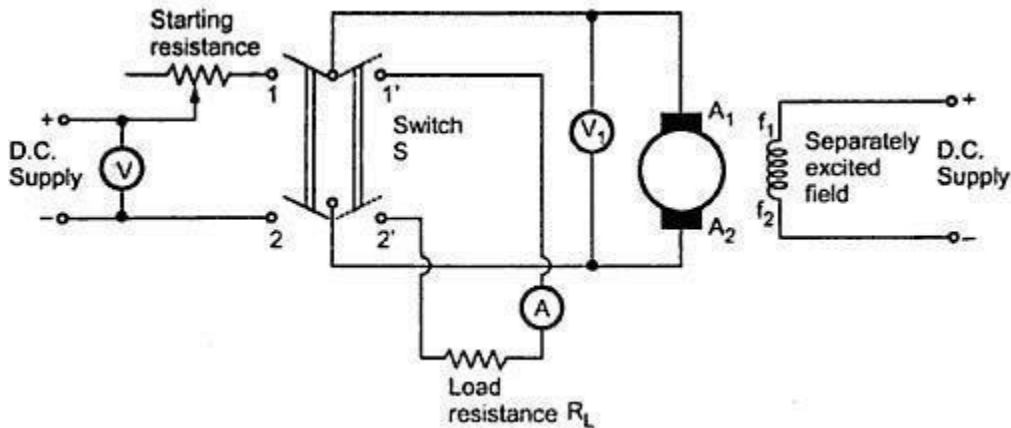

**Fig. 2 Retardation test**

Angular velocity,  $\omega = (2\pi N)/60$

$$W = I \left( \frac{2\pi N}{60} \right) \frac{d}{dt} \left( \frac{2\pi N}{60} \right) = I \left( \frac{2\pi N}{60} \right) \left( \frac{2\pi}{60} \right) \frac{dN}{dt}$$

$\therefore$

$$W = \left( \frac{2\pi}{60} \right)^2 I N \frac{dN}{dt}$$

Thus, to find the rotational losses, the moment of inertia  $I$  and  $dN/dt$  must be known.

These quantities can be found as follows;

### **Determination of $dN/dt$**

The voltmeter  $V_1$  which is connected across the armature will read the back e.m.f. of the motor. We know that back e.m.f. is proportional to speed so that voltmeter is calibrated to read the speed directly.

When motor is cut off from the supply, the speed decrease in speed is noted with the help of stop watch. A curve showing variation between time and speed which is obtained from voltmeter which is suitably calibrated is shown in the Fig. 3.

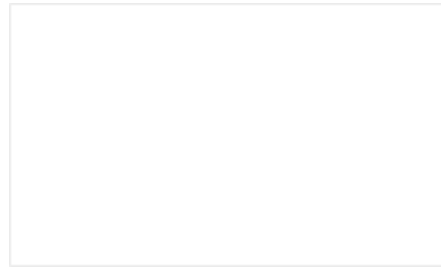
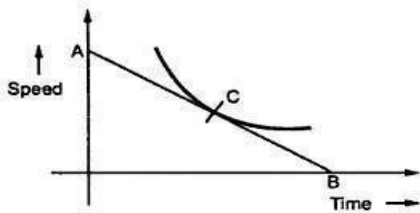

**Fig. 3** Determination of  $dN/dt$

At any point C corresponding to normal speed, a tangent AB is drawn. Then

$$\frac{dN}{dt} = \frac{OA \text{ (in r.p.m.)}}{OB \text{ (in seconds)}}$$

The value obtained from above can be substituted in the expression for W which can give the rotational losses.

### **Determination of moment of inertia (I):**

#### **Method 1: Using Flywheel**

The armature supply is cut off and time required for definite change in speed is noted to draw the corresponding curve as we have drawn in previous case. This curve is drawn considering only armature of the machine. Now a flywheel with known moment of the inertia say is  $I_1$  keyed onto the shaft and the same curve is drawn again. The slowing down time will be extended as combined moment of inertia of the two is increased.

For any given speed ( $dN/dt_1$ ) and ( $dN/dt_2$ ) are determined same as previous case. It can be seen that the losses in both the cases are almost same as addition of flywheel will not make much difference to the losses.

In the first case where flywheel is not there then,

$$W = \left( \frac{2\pi}{60} \right)^2 I N \frac{dN}{dt_1}$$

Adding the flywheel to the motor armature in second case we get,

$$\begin{aligned}
W &= \left(\frac{2\pi}{60}\right)^2 (I + I_1) N \frac{dN}{dt_2} \\
\therefore I N \frac{dN}{dt_1} &= (I + I_1) N \frac{dN}{dt_2} \\
\therefore \frac{I + I_1}{I} &= \frac{(dN / dt_1)}{(dN / dt_2)} \\
\therefore I &= \left[ (I + I_1) \frac{dN}{dt_2} \right] \left/ \left( \frac{dN}{dt_1} \right) \right. \\
\therefore I &= I_1 \times \frac{dN / dt_2}{(dN / dt_1) - (dN / dt_2)} = I_1 \times \frac{dt_1}{dt_2 - dt_1} \\
\therefore \boxed{I} &= \boxed{I_1 \cdot \frac{t_1}{t_2 - t_1}}
\end{aligned}$$

### Method 2: without using Flywheel

In this method time is noted for the machine to slow down by say 5% considering the armature alone. The a retarding torque either mechanical or electrical is applied. Preferably electrical retarding torque is applied and time required to slow down by 5% is noted again. The method by which electrical torque can be provided is shown in the Fig. 1 in which the switch S after disconnecting from the supply is thrown to terminals '12'. The machine then gets connected to a non-inductive load resistance  $R_L$ . The power drawn by this resistance will acts as a retarding torque on the armature which will make it slow more quickly.

The additional loss in the resistance will be equal to product of ammeter reading and the average reading of the voltmeter (for a fall of 5% of voltmeter reading, the time is noted.) The ammeter reading is also changing so its average reading is taken. Thus the additional losses is  $I^2 (R_a + R)$ . Let  $t_1$  be the time

when armature is considered alone and  $t_2$  be the time when armature is connected across a load resistance,  $V$  be average voltage across  $R$  and  $I_a$  be the average current and  $W'$  is additional retarding electrical torque supplied by motor.

$$W = \left(\frac{2\pi}{60}\right)^2 I N \frac{dN}{dt_1}$$

$$W + W' = \left(\frac{2\pi}{60}\right)^2 I N \frac{dN}{dt_2}$$

If  $dN$  i.e. change in speed is same in two cases then

$$\frac{W + W'}{W} = \frac{1/dt_2}{1/dt_1} = \frac{dt_1}{dt_2} = \frac{t_1}{t_2}$$

$$\therefore (W + W') t_2 = W t_1$$

$$\therefore W (t_1 - t_2) = W' t_2$$

$$\therefore \boxed{W = W' \frac{t_2}{t_1 - t_2}}$$

Here  $dN/dt_1$  is rate of change in speed without extra load whereas  $dN/dt_2$  is rate change in speed with extra electrical load which provides retarding torque.

## UNIT V

### SINGLE PHASE TRANSFORMERS

#### WORKING PRINCIPLE OF A TRANSFORMER:

The basic principle on which the transformer works is **Faraday's Law of Electromagnetic Induction** or mutual induction between the two coils. The working of the transformer is explained below. The transformer consists of two separate windings placed over the laminated silicon steel core.

The winding to which AC supply is connected is called primary winding and to which load is connected is called secondary winding as shown in the figure below. It works on the alternating current only because an alternating flux is required for mutual induction between the two windings.

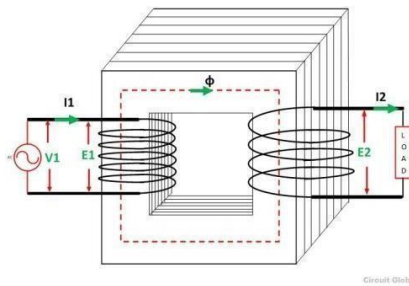

Fig: Simple Transformer

When the AC supply is given to the primary winding with a voltage of  $V_1$ , an alternating flux  $\phi$  sets up in the core of the transformer, which links with the secondary winding and as a result of it, an emf is induced in it called Mutually Induced emf. The direction of this induced emf is opposite to the applied voltage  $V_1$ , this is because of the Lenz's law shown in the figure below

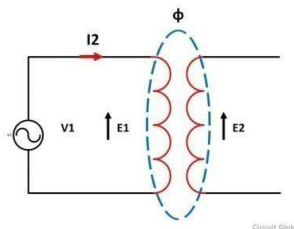

Fig: Transformer Symbol

Physically, there is no electrical connection between the two windings, but they are magnetically connected. Therefore, the electrical power is transferred from the primary circuit to the secondary circuit through mutual inductance. The induced emf in the primary and secondary windings depends upon the rate of change of flux linkage that is  $(N d\phi/dt)$ .

$d\phi/dt$  is the change of flux and is same for both the primary and secondary windings. The induced emf  $E_1$  in the primary winding is proportional to the number of turns  $N_1$  of the primary windings ( $E_1 \propto N_1$ ). Similarly induced emf in the secondary winding is proportional to the number of turns on the secondary side. ( $E_2 \propto N_2$ ).

### **Transformer on DC supply:**

As discussed above, the transformer works on AC supply, and it cannot work on DC supply. If the rated DC voltage is applied across the primary winding, a constant magnitude flux will set up in the core of the transformer and hence there will not be any self-induced emf generation, as for the linkage of flux with the secondary winding there must be an alternating flux required and not a constant flux.

$$\text{Primary Current} = \frac{\text{DC applied voltage}}{\text{Resistance of primary winding}}$$

According to Ohm's Law

The resistance of the primary winding is very low, and the primary current is high. So this current is much higher than the rated full load primary winding current. Hence, as a result, the amount of heat produced will be greater and therefore, eddy current loss ( $I^2R$ ) loss will be more. Because of this, the insulations of the primary windings will get burnt, and the transformer will be damaged.

### **Turn Ratio:**

It is defined as the ratio of primary to secondary turns.

$$\text{Turn ratio} = \frac{N_1}{N_2}$$

If  $N_2 > N_1$  the transformer is called Step up transformer

If  $N_2 < N_1$  the transformer is called Step down transformer

### **Transformation Ratio:**

The transformation ratio is defined as the ratio of the secondary voltage to the primary voltage. It is denoted by  $K$ .

$$K = \frac{E_2}{E_1} = \frac{N_2}{N_1}$$

As ( $E_2 \propto N_2$  and  $E_1 \propto N_1$ )

### **Ideal Transformer:**

Definition: The transformer which is free from all types of losses is known as an ideal transformer. It is an imaginary transformer which has no core loss, no ohmic resistance and no leakage flux. The ideal transformer has the following important characteristic.

1. The resistance of their primary and secondary winding becomes zero.
2. The core of the ideal transformer has infinite permeability. The infinite permeable means less magnetising current requires for magnetising their core.
3. The leakage flux of the transformer becomes zero, i.e. the whole of the flux induces in the core of the transformer links with their primary and secondary winding.
4. The ideal transformer has 100 percent efficiency, i.e., the transformer is free from hysteresis and eddy current loss.

The above mention properties are not possible in the practical transformer. In an ideal transformer, there is no power loss. Therefore, the output power is equal to the input power.

$$E_2 I_2 \cos\phi = E_1 I_1 \cos\phi \quad \text{or} \quad E_2 I_2 = E_1 I_1$$

OR

$$\frac{E_2}{E_1} = \frac{I_1}{I_2}$$

Since  $E_1 \propto N_1$  and  $E_2 \propto N_2$ , also  $E_1$  is similar to  $V_1$  and  $E_2$  is similar to  $V_2$

Therefore, transformation ratio will be given by the equation shown below

$$\frac{V_2}{V_1} = \frac{E_2}{E_1} = \frac{N_2}{N_1} = \frac{I_1}{I_2} = K$$

The primary and the secondary currents are inversely proportional to their respective turns.

### **Behaviour of Ideal Transformer:**

Consider the ideal transformer shown in the figure below. The voltage source  $V_1$  is applied across the primary

winding of the transformer. Their secondary winding is kept open. The  $N_1$  and  $N_2$  are the



numbers of turns of their primary and secondary winding.

The current  $I_m$  is the magnetizing current flows through the primary winding of the transformer. The magnetizing current produces the flux  $\phi_m$  in the core of the transformer. As the permeability of the core is infinite, the flux of the core link with both the primary and secondary winding of the transformer.

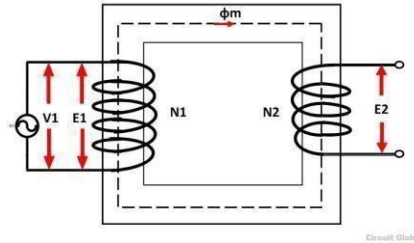
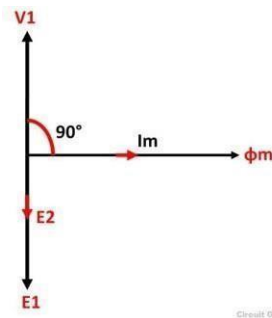

Fig: Ideal Transformer

The flux link with the primary winding induces the emf  $E_1$  because of self-induction. The direction of the induced emf is inversely proportional to the applied voltage  $V_1$ . The emf  $E_2$  induces in the secondary winding of the transformer because of mutual induction.

### Phasor Diagram of Ideal Transformer:

The phasor diagram of the ideal transformer is shown in the figure below. As the coil of the primary transformer is purely inductive the magnetising current induces in the transformer lag  $90^\circ$  by the input voltage  $V_1$ . The  $E_1$  and  $E_2$  are the emf induced in the primary and secondary winding of the transformer.



The direction of the induced emf is inversely proportional to the applied voltage

*Phasor Diagram of an Ideal Transformer*

### Point to Remember

The input energy of the transformer is equal to their output energy. The power loss in the ideal transformer becomes zero.

### EMF EQUATION OF A TRANSFORMER:

When a sinusoidal voltage is applied to the primary winding of a transformer, alternating flux  $\phi_m$  sets up in the iron core of the transformer. This sinusoidal flux links with both primary and secondary winding. The function of flux is a sine function. The rate of change of flux with respect to time is derived mathematically.

The derivation of **EMF Equation** of the transformer is shown below.

- Let  $\phi_m$  be the maximum value of flux in Weber
- $f$  be the supply frequency in Hz
- $N_1$  is the number of turns in the primary winding
- $N_2$  is the number of turns in the secondary winding

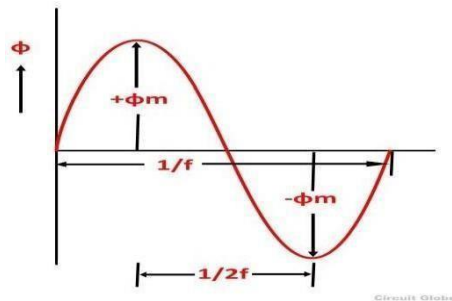

$\Phi$  is the flux per turn in Weber

Fig: Flux waveform

As shown in the above figure that the flux changes from  $+\phi_m$  to  $-\phi_m$  in half a cycle of  $1/2f$  seconds.

By Faraday's Law

$$E_1 = -\frac{d\psi}{dt} \dots \dots \dots (1)$$

Let  $E_1$  is the emf induced in the primary winding

Where  $\Psi = N_1\phi$

$$\text{Therefore, } E_1 = -N_1 \frac{d\phi}{dt} \dots \dots \dots (2)$$

$$E_1 = -N_1 \frac{d}{dt} (\phi_m \sin \omega t)$$

$$E_1 = -N_1 \omega \phi_m \cos \omega t$$

$$E_1 = N_1 \omega \phi_m \sin(\omega t - \pi/2) \dots \dots \dots (3)$$

Since  $\phi$  is due to AC supply  $\phi = \phi_m \sin \omega t$

So the induced emf lags flux by 90

degrees. Maximum value of emf

$$E_1 \text{ max} = N_1 \omega \phi_m \dots \dots \dots (4)$$

$$E_1 \text{ max} = 2\pi f N_1 \phi_m \dots \dots \dots (5)$$

But  $\omega = 2\pi f$

Root mean square RMS value is

$$E_1 = \frac{E_{1\max}}{\sqrt{2}} \dots \dots \dots (6)$$

Putting the value of  $E_{1\max}$  in equation (6) we get

$$E_1 = \sqrt{2}\pi f N_1 \phi_m \dots \dots \dots (7)$$

Putting the value of  $\pi = 3.14$  in the equation (7) we will get the value of  $E_1$  as

$$E_1 = 4.44fN_1 \phi_m \dots \dots \dots (8)$$

$$E_2 = \sqrt{2}\pi f N_2 \phi_m$$

Or

$$E_2 = 4.44fN_2 \phi_m \dots \dots \dots (9)$$

Similarly

Now, equating the equation (8) and (9) we get

$$\frac{E_2}{E_1} = \frac{4.44fN_2 \phi_m}{4.44fN_1 \phi_m}$$

Or

$$\frac{E_2}{E_1} = \frac{N_2}{N_1} = K$$

The above equation is called the turn ratio where  $K$  is known as transformation ratio.

The equation (8) and (9) can also be written as shown below using the relation

( $\phi_m = B_m \times A_i$ ) where  $A_i$  is the iron area and  $B_m$  is the maximum value of flux density.

$$E_1 = 4.44N_1 f B_m A_i \text{ Volts} \quad \text{and} \quad E_2 = 4.44N_2 f B_m A_i \text{ Volts}$$

For a sinusoidal wave

$$\frac{\text{R. M. S value}}{\text{Average value}} = \text{Form factor} = 1.11$$

### **Magnetic Leakage flux:**

In a transformer it is observed that, all the flux linked with primary winding does not get linked with secondary winding. A small part of the flux completes its path through air rather than through the core (as shown in the fig at right), and this small part of flux is called as leakage flux or magnetic leakage in transformers. This leakage flux does not link with both the windings, and hence it does not contribute to

transfer of energy from primary winding to secondary winding. But, it produces self induced emf in each winding. Hence, leakage flux produces an effect equivalent to an inductive coil in series with each winding. And due to this there will be leakage reactance.

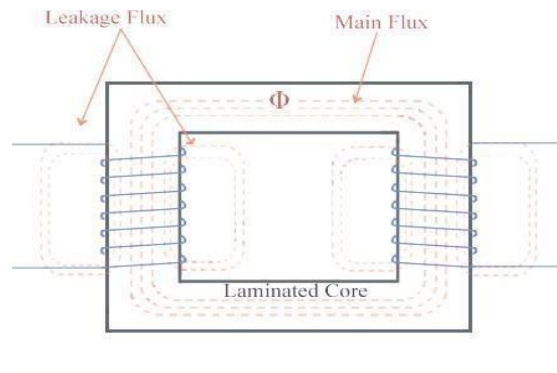

Fig: Magnetic Leakage flux

(To minimize this leakage reactance, primary and secondary windings are not placed on separate legs, refer the diagram of core type and shell type transformer from construction of transformer.)

### Practical Transformer with Resistance and Leakage Reactance

In the following figure, leakage reactance and resistance of the primary winding as well as secondary winding are taken out, representing a practical transformer.

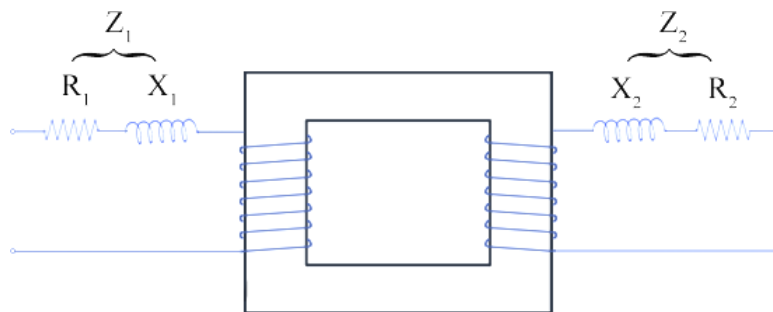

Fig: Practical Transformer with Resistance And Leakage

Reactance Where,  $R_1$  and  $R_2$  = resistance of primary and secondary winding respectively

$X_1$  and  $X_2$  = **leakage reactance** of primary and secondary winding resp.

$Z_1$  and  $Z_2$  = Primary impedance and secondary impedance resp.

$$Z_1 = R_1 + jX_1 \dots \text{and } Z_2 = R_2 + jX_2$$

The impedance in each winding lead to some voltage drop in each winding. Considering this voltage drop the **voltage equation of transformer** can be given as –

$$V_1 = E_1 + I_1(R_1 + jX_1) \quad \text{primary side}$$

$$V_2 = E_2 - I_2(R_2 + jX_2) \quad \text{secondary side}$$

where,  $V_1$  = supply voltage of primary winding

$V_2$  = terminal voltage of secondary winding

$E_1$  and  $E_2$  = induced emf in primary and secondary winding respectively.

### Resistance and Reactance of the Transformer:

The Resistance of the transformer is defined as the internal resistance of both primary and secondary windings. In an actual transformer, the primary and the secondary windings have some resistance represented by  $R_1$  and  $R_2$  and the reactances by  $X_1$  and  $X_2$ . Let  $K$  be the transformation ratio. To make the calculations easy the resistances and reactances can be transferred to either side that means either all the primary terms are referred to the secondary side, or all the secondary terms are referred to the primary side.

The resistive and the reactive drops in the primary and secondary side are represented as

follows □ Resistive drop in the secondary side =  $I_2R_2$

□ Reactive drop in the secondary side =

$I_2X_2$  □ Resistive drop in the primary side =

$I_1R_1$  □ Reactive drop in the primary side =

$I_1X_1$

### Primary Side Referred to Secondary Side

Since the transformation ratio is  $K$ , primary resistive and reactive drop as referred to secondary side will be  $K$  times, i.e.,  $K I_1R_1$  and  $K I_1X_1$  respectively. If  $I_1$  is substituted equal to  $K I_2$  then we have primary

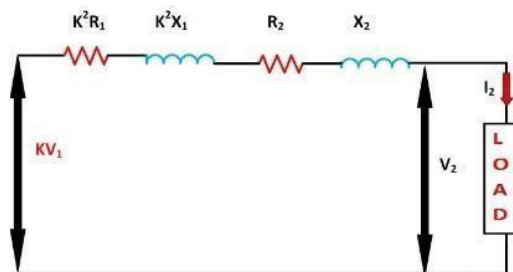

resistive and reactive drop referred to secondary side equal to  $K^2I_2R_1$  and  $K^2I_2X_1$  respectively.

The Total resistive drop in a transformer

$$K^2I_2R_1 + I_2R_2 = I_2 (K^2R_1 + R_2)$$

Total reactive drop in a transformer

$$K^2 I_2 X_1 + I_2 X_2 = I_2 (K^2 X_1 + X_2)$$

The term

$$(K^2 R_1 + R_2) \text{ And } (K^2 X_1 + X_2)$$

represent the equivalent resistance and reactance of the transformer referred to the secondary side.

### **TRANSFORMER ON NO-LOAD CONDITION:**

When the transformer is operating at no load, the secondary winding is open circuited, which means there is no load on the secondary side of the transformer and, therefore, current in the secondary will be zero, while primary winding carries a small current  $I_0$  called no load current which is 2 to 10% of the rated current. This current is responsible for supplying the iron losses (hysteresis and eddy current losses) in the core and a very small amount of copper losses in the primary winding. The angle of lag depends upon the losses in the transformer. The power factor is very low and varies from 0.1 to 0.15.

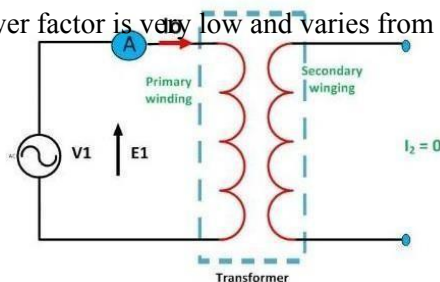

Fig: Transformer is operating at no load The no load current consists of two components

- Reactive or magnetizing component  $I_m$   
(It is in quadrature with the applied voltage  $V_1$ . It produces flux in the core and does not consume any power)
- Active or power component  $I_w$ , also known as working component  
(It is in phase with the applied voltage  $V_1$ . It supplies the iron losses and a small amount of primary copper loss)

The following steps are given below to draw the phasor diagram

1. The function of the magnetizing component is to produce the magnetizing flux, and thus, it will be in phase with the flux.
2. Induced emf in the primary and the secondary winding lags the flux  $\phi$  by 90 degrees.
3. The primary copper loss is neglected, and secondary current losses are zero as  $I_2 = 0$ . Therefore,

the current  $I_0$  lags behind the voltage vector  $V_1$  by an angle  $\phi_0$  called no-load power factor angle shown in the phasor diagram above.

4. The applied voltage  $V_1$  is drawn equal and opposite to the induced emf  $E_1$  because the difference between the two, at no load, is negligible.
5. Active component  $I_w$  is drawn in phase with the applied voltage  $V_1$ .
6. The phasor sum of magnetizing current  $I_m$  and the working current  $I_w$  gives the no load current  $I_0$ .

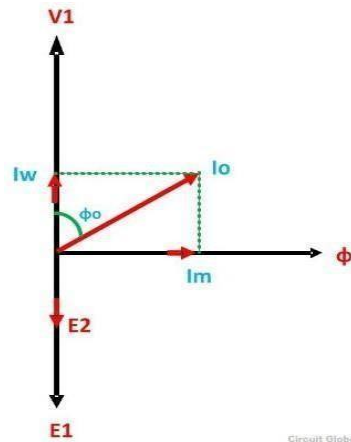

Fig: Phasor diagram drawn

Working component  $I_w = I_0 \cos \phi_0$

No load current  $I_0 = \sqrt{I_w^2 + I_m^2}$

Magnetizing component  $I_m = I_0 \sin \phi_0$

Power factor  $\cos \phi_0 = \frac{I_w}{I_0}$

No load power input  $P_0 = V_1 I_0 \cos \phi_0$

### **TRANSFORMER ON LOAD CONDITION:**

When the transformer is on loaded condition, the secondary of the transformer is connected to load. The load can be resistive, inductive or capacitive. The current  $I_2$  flows through the secondary winding of the transformer. The magnitude of the secondary current depends on the terminal voltage  $V_2$  and the load impedance. The phase angle between the secondary current and voltage depends on the nature of the load.

### **Operation of the Transformer on Load Condition**

The Operation of the Transformer on Load Condition is explained below

- When secondary of the transformer is kept open, it draws the no-load current from the main supply. The no-load current induces the magnetomotive force  $N_0I_0$  and this force set up the flux  $\Phi$  in the core of the transformer. The circuit of the transformer at no load condition is shown in the figure below.

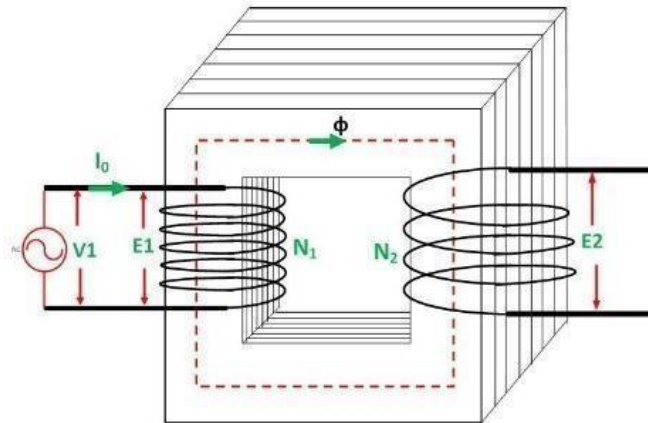

Fig: Operation of the Transformer on Load Condition

- When the load is connected to the secondary of the transformer, the  $I_2$  current flows through their secondary winding. The secondary current induces the magnetomotive force  $N_2I_2$  on the secondary winding of the transformer. This force set up the flux  $\phi_2$  in the transformer core. The flux  $\phi_2$  oppose the flux  $\phi$ , according to Lenz's law

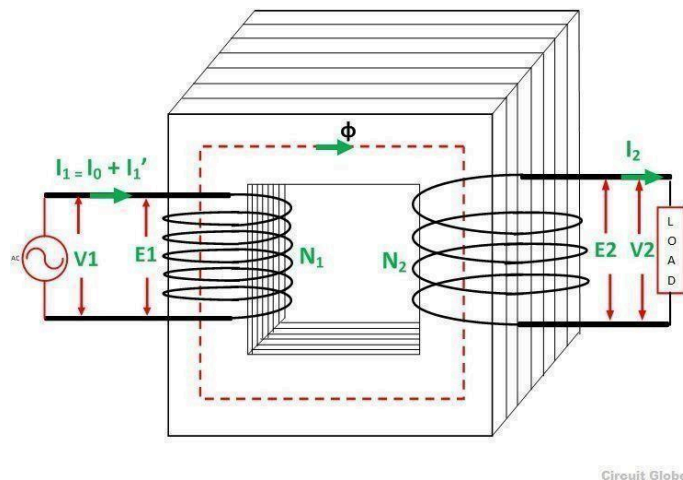

Fig: Operation of the Transformer on Load Condition

- As the flux  $\phi_2$  opposes the flux  $\phi$ , the resultant flux of the transformer decreases and this flux reduces the induced EMF  $E_1$ . Thus, the strength of the  $V_1$  is more than  $E_1$  and an additional primary current



$I_1'$  drawn from the main supply. The additional current is used for restoring the original value of the flux in the core of the transformer so that the  $V_1 = E_1$ . The primary current  $I_1'$  is in phase opposition with the secondary current  $I_2$ . Thus, it is called the primary counter balancing current.

- The additional current  $I_1'$  induces the magnetomotive force  $N_1 I_1'$ . And this force set up the flux  $\phi_1'$ . The direction of the flux is same as that of the  $\phi$  and it cancels the flux  $\phi_2$  which induces because of the MMF  $N_2 I_2$

Now,  $N_1 I_1' = N_2 I_2$

$$I_1' = \left( \frac{N_2}{N_1} \right) I_2 = K I_2$$

Therefore,

- The phasor difference between  $V_1$  and  $I_1$  gives the power factor angle  $\phi_1$  of the primary side of the transformer.
- The power factor of the secondary side depends upon the type of load connected to the transformer.
- If the load is inductive as shown in the above phasor diagram, the power factor will be lagging, and if the load is capacitive, the power factor will be leading. The total primary current  $I_1$  is the vector sum of the current  $I_0$  and  $I_1'$ . i.e

$$\bar{I}_1 = \bar{I}_0 + \bar{I}_1'$$

### **Phasor Diagram of Transformer on Inductive Load:**

The phasor diagram of the actual transformer when it is loaded inductively is shown below

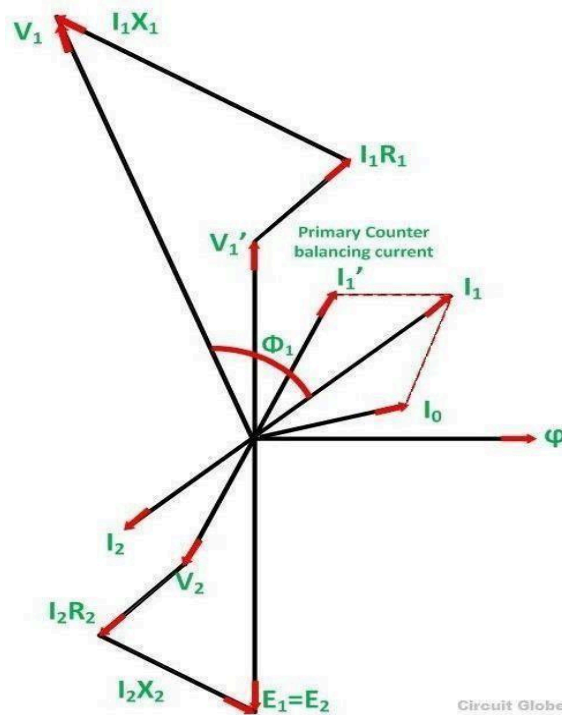

*Phasor Diagram of the Transformer on Inductive Load*

### Steps to draw the phasor diagram

- Take flux  $\phi$  a reference
- Induces emf  $E_1$  and  $E_2$  lags the flux by 90 degrees.
- The component of the applied voltage to the primary equal and opposite to induced emf in the primary winding.  $E_1$  is represented by  $V_1'$ .
- Current  $I_0$  lags the voltage  $V_1'$  by 90 degrees.
- The power factor of the load is lagging. Therefore current  $I_2$  is drawn lagging  $E_2$  by an angle  $\phi_2$ .
- The resistance and the leakage reactance of the windings result in a voltage drop, and hence secondary terminal voltage  $V_2$  is the phasor difference of  $E_2$  and voltage drop.  

$$V_2 = E_2 - \text{voltage drops}$$

$$I_2 R_2 \text{ is in phase with } I_2 \text{ and } I_2 X_2 \text{ is in quadrature with } I_2.$$
- The total current flowing in the primary winding is the phasor sum of  $I_1'$  and  $I_0$ .
- Primary applied voltage  $V_1$  is the phasor sum of  $V_1'$  and the voltage drop in the primary winding.
- Current  $I_1'$  is drawn equal and opposite to the current  

$$I_2 V_1 = V_1' + \text{voltage drop}$$

$$I_1 R_1 \text{ is in phase with } I_1 \text{ and } I_1 X_1 \text{ is in quadrature with } I_1.$$
- The phasor difference between  $V_1$  and  $I_1$  gives the power factor angle  $\phi_1$  of the primary side of the transformer.

- The power factor of the secondary side depends upon the type of load connected to the transformer.
- If the load is inductive as shown in the above phasor diagram, the power factor will be lagging, and if the load is capacitive, the power factor will be leading. Where  $I_1R_1$  is the resistive drop in the primary windings

$I_2X_2$  is the reactive drop in the secondary winding

### Phasor Diagram of Transformer on Capacitive Load

The Transformer on Capacitive load (leading power factor load) is shown below in the phasor diagram.

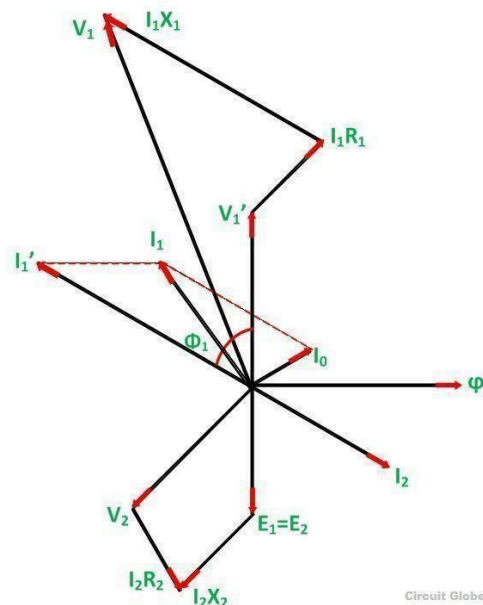

*Phasor Diagram of the Transformer on Capacitive Load*

Steps to draw the phasor diagram at capacitive load

- Take flux  $\phi$  a reference
- Induces emf  $E_1$  and  $E_2$  lags the flux by 90 degrees.
- The component of the applied voltage to the primary equal and opposite to induced emf in the primary winding.  $E_1$  is represented by  $V_1'$ .
- Current  $I_0$  lags the voltage  $V_1'$  by 90 degrees

- The power factor of the load is leading. Therefore current  $I_2$  is drawn leading  $E_2$
- The resistance and the leakage reactance of the windings result in a voltage drop, and hence secondary terminal voltage  $V_2$  is the phasor difference of  $E_2$  and voltage drop.

$$V_2 = E_2 - \text{voltage drops}$$

$I_2 R_2$  is in phase with  $I_2$  and  $I_2 X_2$  is in quadrature with  $I_2$ .

- Current  $I_1'$  is drawn equal and opposite to the current  $I_2$
- The total current  $I_1$  flowing in the primary winding is the phasor sum of  $I_1'$  and  $I_0$ .
- Primary applied voltage  $V_1$  is the phasor sum of  $V_1'$  and the voltage drop in the primary winding.

$$V_1 = V_1' + \text{voltage drop}$$

$I_1 R_1$  is in phase with  $I_1$  and  $I_1 X_1$  is in quadrature with  $I_1$ .

- The phasor difference between  $V_1$  and  $I_1$  gives the power factor angle  $\phi_1$  of the primary side of the transformer.
- The power factor of the secondary side depends upon the type of load connected to the transformer.

### **EQUIVALENT CIRCUIT OF A TRANSFORMER:**

The equivalent circuit diagram of any device can be quite helpful in predetermination of the behaviour of the device under the various condition of operation. It is simply the circuit representation of the equation describing the performance of the device.

The simplified equivalent circuit of a transformer is drawn by representing all the parameters of the transformer either on the secondary side or on the primary side. The equivalent circuit diagram of the transformer is shown below

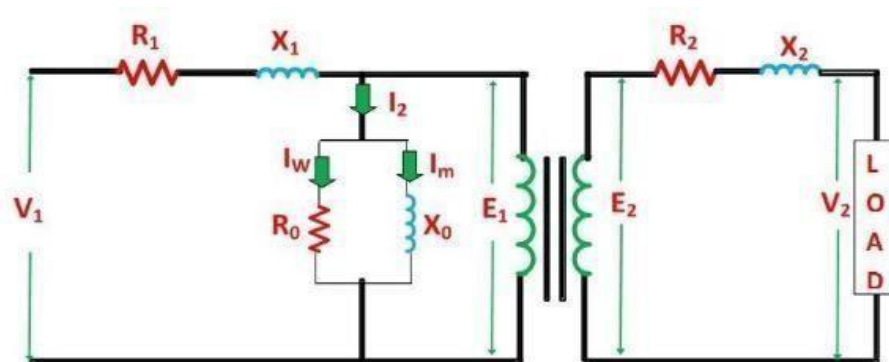

Fig: Equivalent circuit diagram of a transformer

Let the equivalent circuit of a transformer having the transformation ratio  $K = E_2/E_1$

The induced emf  $E_1$  is equal to the primary applied voltage  $V_1$  less primary voltage drop. This voltage

causes current  $I_0$  no load current in the primary winding of the transformer. The value of no-load current is very small, and thus, it is neglected. Hence,  $I_1 = I_1'$ . The no load current is further divided into two components called magnetizing current ( $I_m$ ) and working current ( $I_w$ ).

These two components of no-load current are due to the current drawn by a noninductive resistance  $R_0$  and pure reactance  $X_0$  having voltage  $E_1$  or ( $V_1$  – primary voltage drop).

$$I_2 = \frac{I_1'}{K} = \frac{I_1 - I_0}{K}$$

The secondary current  $I_2$  is

The terminal voltage  $V_2$  across the load is equal to the induced emf  $E_2$  in the secondary winding less voltage drop in the secondary winding.

### Equivalent Circuit when all the Quantities are referred to Primary side:

In this case to draw the equivalent circuit of the transformer all the quantities are to be referred to the primary as shown in the figure below

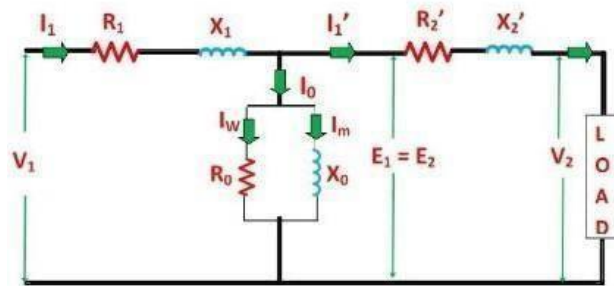

Fig: Circuit Diagram of Transformer when all the Secondary Quantities are Referred to Primary Side

The following are the values of resistance and reactance given below

Secondary resistance referred to primary side is given as

$$R_2' = \frac{R_2}{K^2}$$

The equivalent resistance referred to primary side is given as

$$R_{ep} = R_1 + R_2'$$

Secondary reactance referred to primary side is given as

$$X_2' = \frac{X_2}{K^2}$$

$$X_{ep} = X_1 + X_2'$$

The equivalent reactance referred to primary side is given as

### Equivalent Circuit when all the Quantities are referred to Secondary side:

The equivalent circuit diagram of the transformer is shown below when all the quantities are referred to the secondary side.

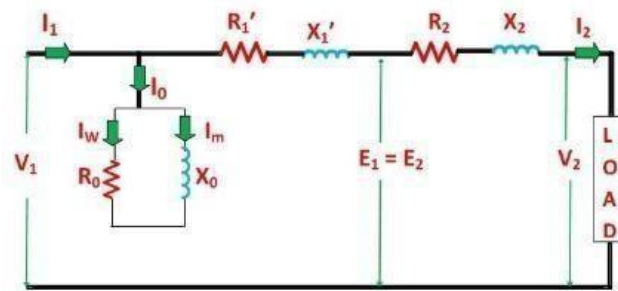

Fig: Circuit Diagram of Transformer When All the Primary Quantities are Referred to Secondary Side

The following are the values of resistance and reactance given below

Primary resistance referred to secondary side is given as

Then  $X_1' = K^2 X_1$  resistance referred to secondary side is given as  
 $X_{eq} = X_2 + X_1'$   
 the equivalent reactance referred to secondary side is given as

No load current  $I_0$  is hardly 3 to 5% of full load rated current, the parallel branch consisting of resistance  $R_0$  and reactance  $X_0$  can be omitted without introducing any appreciable error in the behavior of the transformer under the loaded condition.

Further simplification of the equivalent circuit of the transformer can be done by neglecting the parallel branch consisting  $R_0$  and  $X_0$ . The simplified circuit diagram of the transformer is shown below

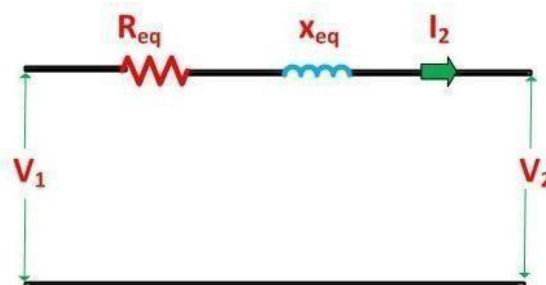

Fig: Simplified Equivalent Circuit Diagram of a Transformer

## VOLTAGE REGULATION OF A TRANSFORMER:

**Definition:** The voltage regulation is defined as the change in the magnitude of receiving and sending the voltage of the transformer. The voltage regulation determines the ability of the transformer to provide the constant voltage for variable loads.

When the transformer is loaded with continuous supply voltage, the terminal voltage of the transformer varies. The variation of voltage depends on the load and its power factor.

$$\text{Voltage Regulation} = \frac{E_2 - V_2}{E_2}$$
$$\% \text{ Voltage Regulation} = \frac{E_2 - V_2}{E_2} \times 100$$

Mathematically, the voltage regulation is represented as

Where,

$E_2$  – secondary terminal voltage at no load

$V_2$  – secondary terminal voltage at full load

$$\% \text{ Voltage Regulation} = \frac{V_1 - E_1}{V_1} \times 100$$

The voltage regulation by considering the primary terminal voltage of the transformer is expressed as,

Let us understand the voltage regulation by taking an example explained below

If the secondary terminals of the transformer are open circuited or no load is connected to the secondary terminals, the no-load current flows through it. If the no current flows through the secondary terminals of the transformer, the voltage drops across their resistive and reactive load become zero. The voltage drop across the primary side of the transformer is negligible.

If the transformer is fully loaded, i.e., the load is connected to their secondary terminal, the voltage drops appear across it. The value of the voltage regulation should always be less for the better performance of transformer.

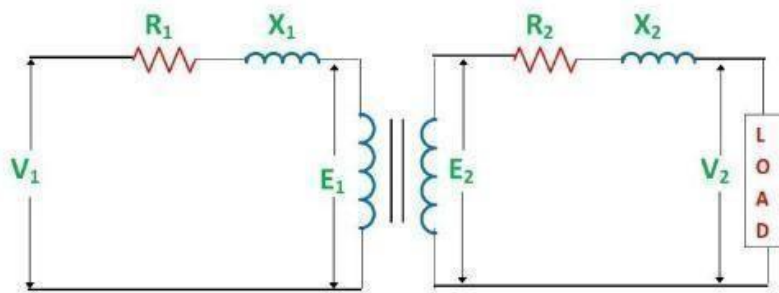

Fig: Equivalent Circuit of transformer

From the circuit diagram shown above, the following conclusions are made

- The primary voltage of the transformer is always greater than the emf induces on the primary side.  $V_1 > E_1$
- The secondary terminal voltage at no load is always greater than the voltage at full load condition.

$E_2 > V_2$  By considering the above circuit diagram, the following equations are drawn

$$V_1 = I_1 R_1 \cos \phi_1 + I_1 X_1 \sin \phi_1 + E_1$$

$$E_2 = I_2 R_2 \cos \phi_2 + I_2 X_2 \sin \phi_2 + V_2$$

The approximate expression for the no-load secondary voltage for the different types of load is

### **For inductive load:**

$$E_2 = I_2 R_{02} \cos \phi_2 + I_2 X_{02} \sin \phi_2 + V_2$$

OR

$$E_2 - V_2 = I_2 R_{02} \cos \phi_2 + I_2 X_{02} \sin \phi_2$$

OR

$$\frac{E_2 - V_2}{E_2} \times 100 = \frac{I_2 R_{02}}{E_2} \times 100 \cos \phi_2 + \frac{I_2 X_{02}}{E_2} \times 100 \sin \phi_2$$

Where,



$\frac{I_2 R_{02}}{E_2} \times 100$  is a percentage resistance drop

$\frac{I_2 X_{02}}{E_2} \times 100$  is a percentage reactance drop

---

**For Capacitive load:**

$$E_2 = I_2 R_{02} \cos \phi_2 - I_2 X_{02} \sin \phi_2 + V_2$$

OR

$$E_2 - V_2 = I_2 R_{02} \cos \phi_2 - I_2 X_{02} \sin \phi_2$$

OR

$$\frac{E_2 - V_2}{E_2} \times 100 = \frac{I_2 R_{02}}{E_2} \times 100 \cos \phi_2 - \frac{I_2 X_{02}}{E_2} \times 100 \sin \phi_2$$

**ALL DAY EFFICIENCY OF A TRANSFORMER:**

**Definition:** All day efficiency means the power consumed by the transformer throughout the day. It is defined as the ratio of output power to the input power in kWh or Wh of the transformer over 24 hours.

Mathematically, it is represented as

$$\text{All day efficiency, } \eta_{\text{all day}} = \frac{\text{output in kWh}}{\text{input in kWh}} \quad (\text{for 24 hours})$$

All day efficiency of the transformer depends on their load cycle. The load cycle of the transformer means the repetitions of load on it for a specific period.

The ordinary or commercial efficiency of a transformer define as the ratio of the output power to the input power.

$$\eta = \frac{\text{output power}}{\text{input power}} = \frac{\text{output power}}{\text{output power} + \text{losses}}$$

**What is the need of All Day Efficiency?**

Some transformer efficiency cannot be judged by simple commercial efficiency as the load on certain transformer fluctuates throughout the day. For example, the distribution transformers are energised for 24 hours, but they deliver very light loads for the major portion of the day, and they do not supply rated or full load, and most of the time the distribution transformer has 50 to 75% load on it.

As we know, there are various losses in the transformer such as iron and copper loss. The iron loss takes place in the core of the transformer. Thus, the iron or core loss occurs for the whole day in the distribution transformer. The second type of loss known as copper loss takes place in the windings of the transformer also known as the variable loss. It occurs only when the transformers are in the loaded condition.

Hence, the performance of such transformers cannot be judged by the commercial or ordinary efficiency, but the efficiency is calculated or judged by All Day Efficiency also known as operational efficiency or energy efficiency which is computed by energy consumed during 24 hours.

### **POLARITY TEST OF TRANSFORMER:**

**Polarity** means the direction of the induced voltages in the primary and the secondary winding of the transformer. If the two transformers are connected in parallel, then the polarity should be known for the proper connection of the transformer. There are two types of polarity one is **Additive**, and another is **Subtractive**.

**Additive Polarity:** In additive polarity the same terminals of the primary and the secondary windings of the transformer are connected

**Subtractive Polarity:** In subtractive polarity different terminals of the primary and secondary side of the transformer are connected.

### **Explanation with Connection Diagram:**

Each of the terminals of the primary as well as the secondary winding of a transformer is alternatively positive and negative with respect to each other as shown in the figure below. Let  $A_1$  and  $A_2$  be the positive and negative terminal respectively of the transformer primary and  $a_1$ ,  $a_2$  are the positive and negative terminal of the secondary side of the transformer.

If  $A_1$  is connected to  $a_1$  and  $A_2$  is connected to  $a_2$  that means similar terminals of the transformer are connected, then the polarity is said to be additive. If  $A_1$  is connected to  $a_2$  and  $A_2$  to  $a_1$ , that means the opposite terminals are connected to each other, and thus the voltmeter will read the subtractive polarity.

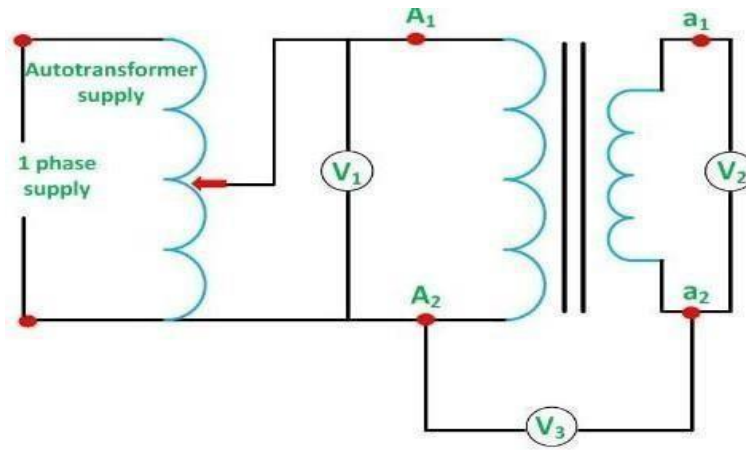

Fig: Polarity test

It is essential to know the relative polarities at any instant of the primary and the secondary terminals for making the correct connections if the transformers are to be connected in parallel or they are used in a three phase circuit.

In the primary side, the terminals are marked as  $A_1$  and  $A_2$  and from the secondary side the terminals are named as  $a_1$  and  $a_2$ . The terminal  $A_1$  is connected to one end of the secondary winding, and a voltmeter is connected between  $A_2$  and the other end of the secondary winding.

When the voltmeter reads the difference that is  $(V_1 - V_2)$ , the transformer is said to be connected with opposite polarity known as Subtractive polarity and when the voltmeter reads  $(V_1 + V_2)$ , the transformer is said to have additive polarity.

### **Steps to Perform Polarity Test:**

- Connect the circuit as shown in the above circuit diagram figure and set the autotransformer to zero position.
- Switch on the single phase supply
- Records the values of the voltages as shown by the voltmeter  $V_1$ ,  $V_2$  and  $V_3$ .
- If the reading of the  $V_3$  shows the addition of the value of  $V_1$  and  $V_2$  that is  $V_3 = V_1 + V_2$  the transformer is said to be connected in additive polarity.
- If the reading of the  $V_3$  is the subtraction of the readings of  $V_1$  and  $V_2$ , then the transformer is said to be connected in subtractive or negative polarity.

### **RESISTANCE MEASUREMENT:**

This test is a verification that proper sizes of conductors have been used and that the joints have

been made properly. Since this test is indicative in nature, there is no tolerance applicable to the measured resistances. Resistances of the windings are measured by using 'Resistance Bridge'.

This test also serves two other important testing functions:

- (a) The measured resistance is used for obtaining  $I^2 R$ , which is used in the 'Load loss' test.
- (b) Measurements of cold resistance and hot resistance are used for calculation of temperature rise of windings during the Temperature Rise Test.

The measurement of resistance is done at room temperature but corrected to a reference temperature which is 20 degrees higher than the temperature class of the unit. For example : the reference temperature is 75 °C for 55 °C rise oil-filled units, or is 85 °C for 65 °C rise units. For dry type transformers the typical rises are 80°C, 115 °C and 150 °C.

### **OPEN CIRCUIT AND SHORT CIRCUIT TEST ON TRANSFORMER**

The open circuit and short circuit test are performed for determining the parameter of the transformer like their efficiency, voltage regulation, circuit constant etc. These tests are performed without the actual loading and because of this reason the very less power is required for the test. The open circuit and the short circuit test gives the very accurate result as compared to the full load test.

#### **Open Circuit Test:**

The purpose of the open circuit test is to determine the no-load current and losses of the transformer because of which their no-load parameter are determined. This test is performed on the primary winding of the transformer. The wattmeter, ammeter and the voltage are connected to their primary winding. The nominal rated voltage is supplied to their primary winding with the help of the ac source.

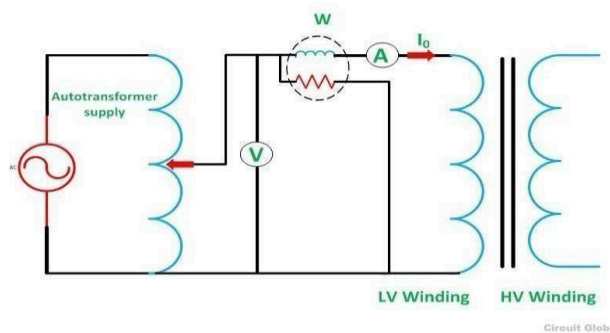

Fig: Circuit Diagram of Open Circuit Test on Transformer

The secondary winding of the transformer is kept open and the voltmeter is connected to their terminal. This voltmeter measures the secondary induced voltage. As the secondary of the transformer is open the

no-load current flows through the primary winding.

The value of no-load current is very small as compared to the full rated current. The copper loss occurs only on the primary winding of the transformer because the secondary winding is open. The reading of the wattmeter only represents the core and iron losses. The core loss of the transformer is same for all types of loads.

**Calculation of open circuit test:**

Let,

$W_0$  – wattmeter reading

$V_1$  – voltmeter reading

$I_0$  – ammeter reading

Then the iron loss of the transformer  $P_i = W_0$  and

$$W_0 = V_1 I_0 \cos \phi_0 \dots \dots \dots (1)$$

The no-load power factor is

$$\cos \phi_0 = \frac{W_0}{V_1 I_0}$$

Working component  $I_w$  is

$$I_w = \frac{W_0}{V_1} \dots \dots \dots (2)$$

Putting the value of  $W_0$  from the equation (1) in equation (2) you will get the value of working component as

$$I_w = I_0 \cos \phi_0$$

$$I_m = \sqrt{I_0^2 - I_w^2}$$

Magnetizing component is

No load parameters are given below Equivalent exciting resistance is

$$R_0 = \frac{V_1}{I_w}$$

Equivalent exciting reactance is

$$X_0 = \frac{V_1}{I_m}$$

The iron losses measured by the open circuit test are used for calculating the efficiency of the transformer.

### Short Circuit Test:

The short circuit test is performed for determining the below mention parameter of the transformer.

- It determines the copper loss occur on the full load. The copper loss is used for finding the efficiency of the transformer.
- The equivalent resistance, impedance, and leakage reactance are known by the short circuit test.

The short circuit test is performed on the secondary or high voltage winding of the transformer. The measuring instrument like wattmeter, voltmeter and ammeter are connected to the High voltage winding of the transformer. Their primary winding is short circuited by the help of thick strip or ammeter which is connected to their terminal.

The low voltage source is connected across the secondary winding because of which the full load current flows from both the secondary and the primary winding of the transformer. The full load current is measured by the ammeter connected across their secondary winding.

The circuit diagram of the short circuit test is shown below

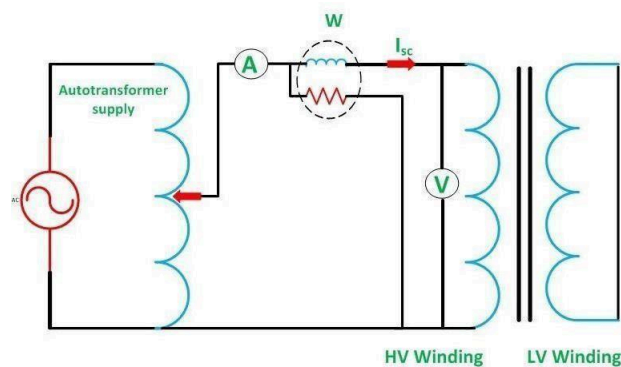

Circuit Globe

Fig: Circuit Diagram of Short Circuit Test on Transformer

The low voltage source is applied across the secondary winding which is approximately 5 to 10% of the normal rated voltage. The flux is set up in the core of the transformer. The magnitude of the flux is small as compared to the normal flux.

The iron loss of the transformer depends on the flux. It is less occur in the short circuit test because of the low value of flux. The reading of the wattmeter only determines the copper loss occur on their windings. The voltmeter measures the voltage applied to their high voltage winding. The secondary current induces in the transformer because of the applied voltage.

### Calculation of Short Circuit Test

Let,

$W_c$  – Wattmeter reading

$V_{2sc}$  – voltmeter reading

$I_{2sc}$  – ammeter reading

Then the full load copper loss of the transformer is given by

$$P_c = \left(\frac{I_{2fl}}{I_{2sc}}\right)^2 W_c \quad \text{And} \quad I_{2sc}^2 R_{es} = W_c$$

$$R_{es} = \frac{W_c}{I_{2sc}^2}$$

Equivalent resistance referred to secondary side is

Equivalent impedance referred to the secondary side is given by

$$Z_{es} = \frac{V_{2sc}}{I_{2sc}}$$

The Equivalent reactance referred to the secondary side is given by

$$X_{es} = \sqrt{(Z_{es})^2 - (R_{es})^2}$$

The voltage regulation of the transformer can be determined at any load and power factor after knowing the values of  $Z_{es}$  and  $R_{es}$ .

In the short circuit test the wattmeter record, the total losses including core loss but the value of core loss are very small as compared to copper loss so, the core loss can be neglected.

### BACK-TO-BACK TEST (SUMPNER'S TEST) ON TRANSFORMER

**Definition:** The full load test on a small transformer is very convenient, but on the large transformer, it is very difficult. The maximum temperature rise in a large transformer is determined by the full load test. This test is called, back-to-back test, regenerative test or Sumpner's test.

The suitable load which absorbs the full load power of a large transformer will not easily be available. Hence a large amount of energy will be wasted. The back-to-back test determines the maximum temperature rise in a transformer, and hence the load is chosen according to the capability of the transformer.

### Back to Back Test Circuit:

The two identical transformers are used for the back to back test. Consider the  $T_{r1}$  and  $T_{r2}$  are the primary windings of the transformer connected parallel to each other. The nominal rated voltage and frequency is supplied to their primary winding. The voltmeter and ammeter are connected on their primary side for the measurement of the input voltage and current.

The secondary winding of the transformer is connected in series with the each other but with opposite polarity. The voltmeter  $V_2$  is connected to the terminal of the secondary winding for the measurement of the voltage.

The series opposition of the secondary winding is determined by connecting there any two terminals; the voltmeter is connected across their remaining terminals. If it is connected in series opposition, the voltmeter gives the zero reading. The open terminal is used for measuring the parameter of the transformer.

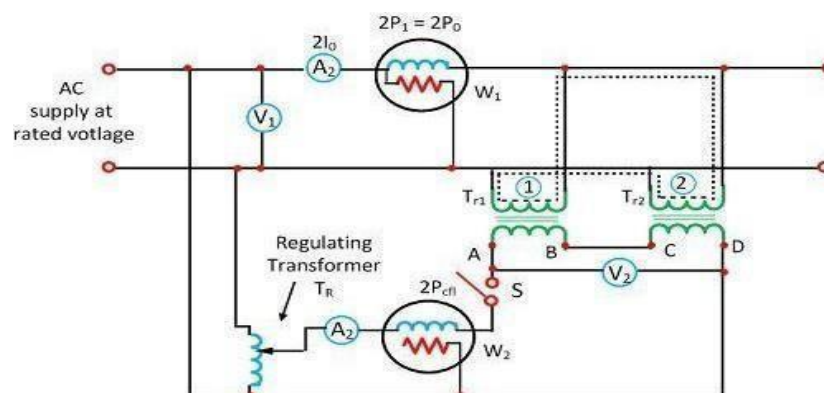

Back-to-back test on two identical single-phase transformers



The above figure shows that the terminal B and C are connected to each other, and the voltage is measured across the terminal A and D.

### **Finding Losses with Sumpner's Test on Transformer**

The secondaries of the transformer are so connected that their potentials are in opposition to each other. This would so if  $V_{AB} = V_{CD}$  and A is joined to C whilst B is joined to D. In that case, there would be no secondary current flowing around the loop formed by the two secondaries. T is an auxiliary low-voltage transformer [Regulation Transformer]. which can be adjusted to give a variable voltage and hence current in the secondary loop circuit. By proper adjustment of T, full-load secondary current  $I_2$  can be made to flow as shown. It is seen, that  $I_2$  flows from D to C and then from A to B. Flow of  $I_1$  is confined to the loop FEJLGHMF and it does not pass through W1. Hence, W1 continues to read the core loss and W2 measures full-load  $Cu$  loss (or at any other load current value  $I_2$ ). Obviously, the power taken in is twice the losses of a single transformer.

i.e. copper loss per transformer  $P_{Cu} = W_2/2$ .

i.e. iron loss per transformer  $P_i = W_1/2$ .

From results of sumpner's test, the full load efficiency of each transformer can be given as

$$\% \text{ full load efficiency of each transformer} = \frac{\text{output}}{\text{output} + \frac{W_1}{2} + \frac{W_2}{2}} \times 100$$

### ***Advantages of Sumpner's Test***

1. Low power is required to conduct this test. Because no external load is connecting
2. Full load copper losses and iron losses of both transformers determined.
3. Increase in transformer temperature can be found.

### **Determination of Temperature Rise**

The temperature rise of the transformer is determined by measuring the temperature of their oil after every particular interval of time. The transformer is operating back to back for the long time which increases their oil temperature. By measuring the temperature of their oil the withstand capacity of the transformer under high temperature is determined.

### **Determination of Iron Loss**

The wattmeter  $W_1$  measures the power loss which is equal to the iron loss of the transformer. For determining the iron loss, the primary circuit of the transformer is kept closed. Because of the primary closed circuit, no current flows through the secondary windings of the transformer. The secondary winding behaves like an open circuit. The wattmeter is connected to their secondary terminal for the measurement of iron loss.

### **Determination of Copper Loss**

The copper loss of the transformer is determined when the full load current flows through their primary and secondary windings. The additional regulating transformer is used for exciting the secondary windings. The full load current flows from the secondary to the primary winding. The wattmeter  $W_2$  measures the full load copper loss of the two transformers.

## **PARALLEL OPERATION OF TRANSFORMERS**

Sometimes, it becomes necessary to connect more than one transformer's in parallel, for example, for supplying excess load of the rating of existing transformer. If two or more transformers are connected to a same supply on the primary side and to a same load on the secondary side, then it is called as parallel operation of transformers.

### **Necessity of Parallel Operation of Transformers:**

Why parallel operation of transformers is needed?

- **Increased Load:** When load is increased and it exceeds the capacity of existing transformer, another transformer may be connected in parallel with the existing transformer to supply the increased load.
- **Non-availability of large transformer:** If a large transformer is not available which can meet the total requirement of load, two or more small transformers can be connected in parallel to increase the capacity.
- **Increased reliability:** If multiple transformers are running in parallel, and a fault occurs in one transformer, then the other parallel transformers still continue to serve the load. And the faulty transformer can be taken out for the maintenance.
- **Transportation is easier for small transformers:** If installation site is located far away, then transportation of smaller units is easier and may be economical.

### **Conditions for parallel operation of Transformers:**

There are various conditions that must fulfill for the successful operation of transformers as follows.

1. The line voltage ratio of two transformers must be equal.
2. The per unit impedance of each transformer should be equal and they should have same ratio of

equivalent leakage reactance to the equal resistance( $X/R$ ).

3. The transformers should have same secondary winding polarity.
4. The Transformers should have same phase sequence (Three phase transformer)
5. The transformers should have the zero relative phase replacement between the secondary line voltages.(Three phase transformers)

### **1) The line voltage ratios of the two transformers must be equal**

This condition is used to avoid the inequality EMF induction at the two secondary windings. If the two transformers connected in parallel have slightly different voltage ratios, then due the inequality of induced emfs in the secondary voltages, a circulating current will flow in a loop format in the secondary windings. This current is greater than the no load current and will be quite high due to less leakage impedance

during load. When the secondary windings are loaded, this circulating current will tend to unequal loading on two transformers and one transformer may be over loaded and another may be less loaded.

### **2) Equal per unit leakage impedance**

If the ratings or line voltages are equal their per unit leakage impedance's should be equal in order to have equal load sharing of the both transformers. If the ratings are unequal then the transformer which has less rating will draw more current and it leads to unequal load sharing. It may also lead to mismatch in line voltages due to voltage drops. In other words, for unequal ratings, the numerical values of their impedance's should be in inverse proportional to their ratings to have current in them in line with their ratings.

A difference in the ratio of the reactance value to the resistance value of the impedance results in different phase angles of the currents carried by the two parallel transformers. Due to this phase angle difference between voltage and current, one transformer may be working on high power factor and another transformer may be working on lower factor. Hence real power sharing is not proportional between the two transformers.

### **3) The transformers should have same secondary winding polarity**

The transformers should be properly connected with regards to their polarity. If they are connected with in correct polarities then the two emf's induced in the secondary winding which are in parallel, will act together and produce a short circuit between the two of them. Total loss of power supply and high damage to the transformers.

### **4) The Transformers should have same phase sequence**

In case of three winding transformers in-addition to the above conditions the phase sequence of line voltages of the both transformers must be identical for parallel operation. If the phase sequence is not

correct in every voltage cycle each pair of phases will get shorted

**5) The transformers should have zero relative phase displacement between the secondary line voltages**

This condition indicates that the two secondary line voltages should have zero phase displacement which avoids UN-intended short circuit between the phases of two windings.

There are four groups which in to which the three phase windings connections are classified:

- Group 1: Zero phase displacement (Yy0,Dd0,Dz0)
- Group2: 180° Phase displacement (Yy6,Dd6,Dz6)
- Group3: -30° Phase displacement (Ys1,Dy1,Yz1)
- Group4: +30° Phase displacement(Yd11,Dy11,Yz11)

The letters Y,D and z represents the Star, Delta and zigzag type winding connections. In order to have zero phase displacement of secondary side line voltages, the transformers belonging to the same group can be paralleled. For example with Yd1 and Dy1 can be paralleled. The transformers of groups 1 and 2 can be paralleled with their own group where as the transformers of group 3 and 4 can be paralleled by revering the phase sequence of one of them. For example a transformer with Yd11 connection of group 4 can be paralleled with that having Dy1 connection by reversing the phase sequence of both primary and secondary terminals of the Dy1 transformer.

**OPEN DELTA CONNECTION:**

In three phase systems, the use of transformers with three windings (or legs) per side is common. These three windings are often connected in delta or star, resulting in common transformer configurations such as delta-delta or delta-star. An open delta transformer is a special arrangement which uses only two windings.

**Transformer Configuration**

The illustration shows how an open delta transformer is connected. On both the primary and secondary there are only two windings. Even in this configuration, it is still possible to transform a three phase voltage.

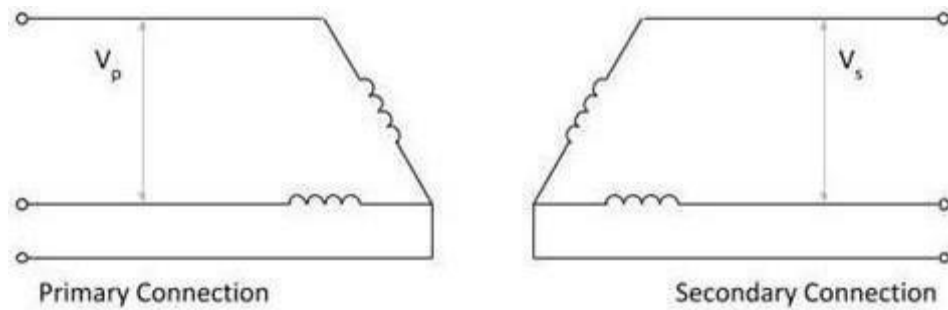

### Open Delta Transformer

Open delta transformers are not commonly used. Typically they would be used for small loads where cost is important. Alternatively, they could be used as an emergency measure, should one winding only of a transformer fail.

Sometimes you may hear an open delta transformer referred to as a V-connection transformer.

### Power Delivered:

Sometimes the power delivered by an open delta transformer is compared to that of an equivalent three winding transformer. Typically figures like having 57.7% of the capacity of an equivalent three winding transformer or 87% of two transformers (same winding size) are quoted. While you can think of the transformer in this manner, it is more fruitful not to consider comparisons but to the necessary calculations on the open delta transformer.

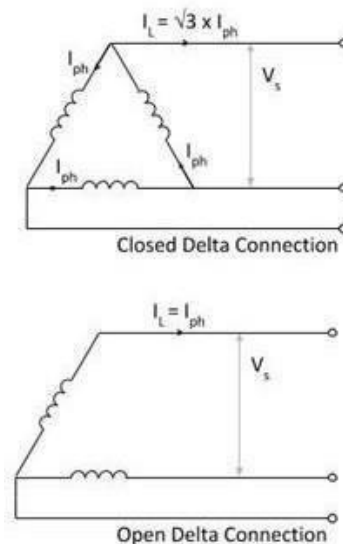

Consider the illustration, showing the output from both a close delta and open delta transformer. Note, that in the delta connection to line current is  $\sqrt{3}$  times the phase current, whereas in the open delta, they are the same.

The transformer output power (in VA) is for a balanced transformer system for the closed delta connection (using phase current), this give:

$$VA=3V_L I_{ph}$$

And for the open delta connection:

$$VA= I_{ph}$$

Taking the ratio of open delta to closed delta power, gives:

$$=0.577(\text{or } 57.7\%)$$

Open delta transformers are three phase devices, with only two windings on each of the primary and secondary sides. While cheaper than a conventional three winding transformer, the open delta will only deliver 57.7% of the power of a conventional transformer (not two thirds, 66.7% as may be expected). There is limited adoption of open delta transformers, although they can be useful in certain situations.

### **Power Factor with Two Transformers in 3-Phase Open-Delta Configuration:**

The power factor of a typical T/F is 0.866, so the max output (KVA) of a T/F will be 86.6% of its rated capacity. Suppose we have three transformers each having the same rating (50 KVA). Then the total capacity is equal to  $150 * 0.866=130$  KVA and not 150 KVA. (The factor 0.866 is called the Utility Factor.)

If one transformer is removed, the total output of two T/Fs will be  $100 * 0.866=86.6$  KVA. From this calculation, we see that output capacity is reduced when a Delta-Delta configuration is operated as an Open-Delta connection, i.e. with one T/F removed.

Let say the two T/Fs of Open-Delta configuration are supplying 3-phase power to a load having power factor  $\text{Cos}\alpha$ . The power factor of one T/F is  $\text{Cos}(30-\alpha)$  and the other is  $\text{Cos}(30+\alpha)$ .

$$\text{Power (T/F1)}=\text{KVA } \text{Cos}(30-\alpha) \text{ and}$$

$$\text{Power(T/F2)}= \text{KVACos}(30+\alpha)$$

- Case (i): When phase angle ( $\alpha=0$ ) is zero, mean load p.f=1 - each transformer has power factor  
=  $\text{Cos}30 = 0.866$

- Case (ii): When phase angle is  $30^\circ (\alpha=30)$ , mean load p.f.=0.866, one T/F will have p.f of  $\cos(30-30) = \cos 0 = 1$  and the other will be operating at p.f of  $\cos(30+30) = \cos 60 = 0.866$
- Case (iii): When phase angle is  $60^\circ (\alpha=60)$ , mean load p.f.=0.5, then one T/F will have p.f of  $\cos(30-60) = 0.866$  and other will have a p.f of  $\cos(30+60) = \cos 90 = 0$ .

From the third scenario we conclude that if we have a transformer Open-Delta configuration in which one T/F is transferring power to an entire load at a p.f of 0.866, then the other one will not provide any load.

### Applications of Open-Delta configurations:

- Widely used for small 3-phase loads.
- Used in applications where the current load is less, and may increase in future.
- There is no relative shift in output, so can be used for unbalanced loads and where harmonics are involved.

### SCOTT CONNECTION OF TRANSFORMERS:

**Definition:** The Scott-T Connection is the method of connecting two single phase transformer to perform the 3-phase to 2-phase conversion and vice-versa. The two transformers are connected electrically but not magnetically. One of the transformers is called the main transformer, and the other is called the auxiliary or teaser transformer.

The figure below shows the Scott-T transformer connection. The main transformer is centre tapped at D and is connected to the line B and C of the 3-phase side. It has primary BC and secondary  $a_1a_2$ . The teaser transformer is connected to the line terminal A and the centre tapping D. It has primary AD and the secondary  $b_1b_2$

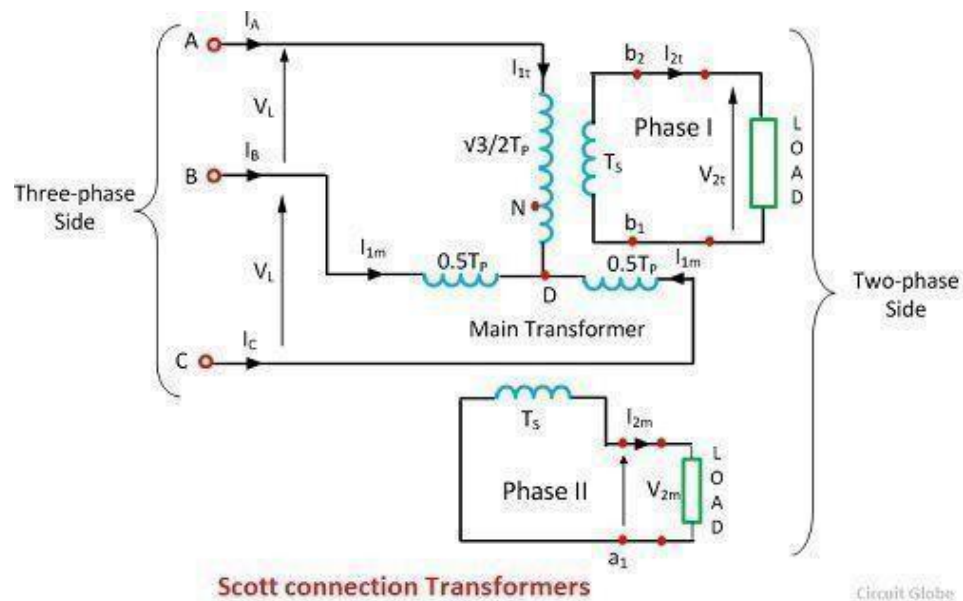



The identical, interchangeable transformers are used for Scott-T connection in which each transformer has a primary winding of  $T_p$  turns and is provided with tapping at  $0.289T_p$ ,  $0.5T_p$  and  $0.866 T_p$ .

### Phasor Diagram of Scott Connection Transformer

The line voltages of the 3-phase system  $V_{AB}$ ,  $V_{BC}$ , and  $V_{CA}$  which are balanced are shown in the figure

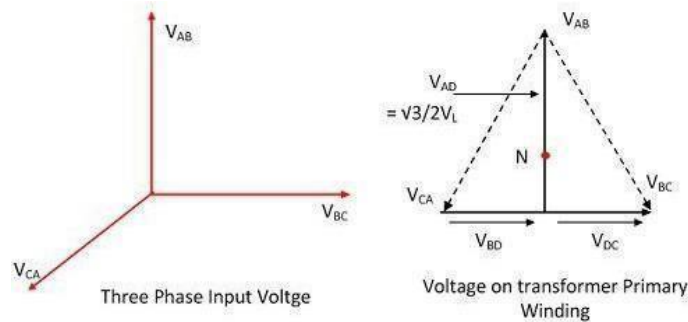

below. The same voltage is shown as a closed equilateral triangle. The figure below shows the primary windings of the main and the teaser transformer.

$$|V_{AB}| = |V_{BC}| = |V_{CA}| = |V_L|$$

The D divides the primary BC of the main transformers into two halves and hence the number of turns in portion BD = the number of turns in portion DC =  $T_p/2$ . The voltage  $V_{BD}$  and  $V_{DC}$  are equal, and they are

$$V_{BD} = V_{DC} = \frac{1}{2} V_{BC} = \frac{1}{2} V_L < 0^\circ$$

in phase with  $V_{BC}$ .

The voltage between A and D is

$$V_{AD} = V_L \left( -\frac{1}{2} + j \frac{\sqrt{3}}{2} \right) + \frac{1}{2} V_L$$

$$V_{AD} = V_L \left( j \frac{\sqrt{3}}{2} \right) = 0.866 V_L < 90^\circ$$

The teaser transformer has the primary voltage rating that is  $\sqrt{3}/2$  or 0.866 of the voltage ratings of the main transformer. Voltage  $V_{AD}$  is applied to the primary of the teaser transformer and therefore the secondary of the voltage  $V_{2t}$  of the teaser transformer will lead the secondary terminal voltage  $V_{2m}$  of the main transformer by  $90^\circ$  as shown in the figure below.

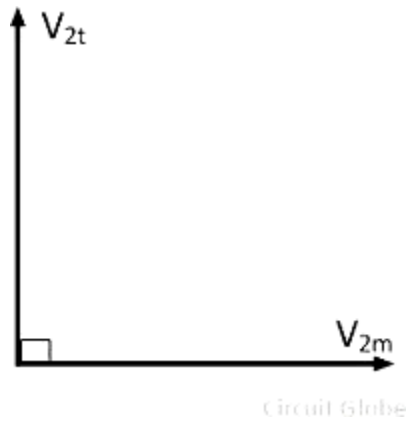

Fig: secondary Phasor diagram

Then,

$$\frac{V_{S_1}}{V_{AD}} = \frac{T_S}{T_{AD}}$$

$$V_{2t} = \frac{T_S}{T_{AD}} V_{AD} = \frac{T_S}{\frac{\sqrt{3}}{2} T_P} \times \frac{\sqrt{3} V_t}{2}$$

$$\frac{T_S}{T_P} V_L = v_{2m}$$

For keeping the voltage per turn same in the primary of the main transformer and the primary of the teaser transformer, the number of turns in the primary of the teaser transformer should be equal to  $\sqrt{3}/2T_p$ .

---

Thus, the secondaries of both transformers should have equal voltage ratings. The  $V_{21}$  and  $V_{2m}$  are equal in magnitude and  $90^\circ$  apart in time; they result in the balanced 2-phase system.

### Position of Neutral Point (N)

The primary of the two transformers may have a four wire connection to a 3-phase supply if the tapping N is provided on the primary of the teaser transformer such that

The voltage across AN =  $V_{AN}$  = phase voltage =  $V_L/\sqrt{3}$ .

Since the voltage across the portion AD.

$$V_{AD} = \frac{\sqrt{3}}{2} V_L$$

the voltage across the portion ND

$$V_{ND} = V_{AD} - V_{AN} = \frac{\sqrt{3}}{2} V_L - \frac{V_L}{\sqrt{3}} = \frac{V_L}{2\sqrt{3}}$$

The same voltage turn in portion AN, ND and AD are shown by the equations,

$$T_{AN} = \frac{T_P}{\sqrt{3}} = 0.577T_P$$

$$T_{ND} = \frac{T_P}{2\sqrt{3}} = 0.288T_P$$

$$T_{AD} = \frac{\sqrt{3}T_P}{2} = 0.866T_P$$

$$\frac{T_{AN}}{T_{ND}} = \frac{T_P}{\sqrt{3}} + \left( \frac{T_P}{2\sqrt{3}} \right) = 2$$

The equation above shows that the neutral point N divides the primary of the teaser transformer in ratio.

AN : ND = 2 : 1

### Applications of Scott Connection:

The following are the applications of the Scott-T connection.

1. The Scott-T connection is used in an electric furnace installation where it is desired to operate two single-phase together and draw the balanced load from the three-phase supply.
2. It is used to supply the single phase loads such as electric train which are so scheduled as to keep the load on the three phase system as nearly as possible.
3. The Scott-T connection is used to link a 3-phase system with a two-phase system with the flow of power in either direction.

The Scott-T connection permits conversions of a 3-phase system to a two-phase system and vice versa. But since 2-phase generators are not available, the converters from two phases to three phases are not used in practice.

## **AUTOTRANSFORMER**

A Transformer, in which a part of the winding is common to both the Primary and Secondary circuit, is called an Auto Transformer. It shall be noted that in Two Winding Transformer, Primary and Secondary windings are electrically isolated but in Auto Transformer, the two windings are not electrically isolated.

### **Why do we need to go for Auto Transformer?**

We have some advantages of auto-transformer over normal two winding transformers.

1. Autotransformers usually smaller in size, because one winding is eliminated.
2. As size is small cost also low(so cheap in cost)
3. As the winding is same so leakage reactance will be less.
4. Increased kVA rating.

### **PRINCIPLE OF OPERATION OF AUTOTRANSFORMER:**

The principle of operation of the transformer is the same as the one of the common transformer, and then the relation between input and output voltages and input and output currents and the ratio of number of turns between the primary and the secondary winding is the same.

The currents of the primary and secondary windings are flowing on the opposite directions, so the total current flowing through the common part of the winding is equal to the difference between the current on the low-voltage winding and the current on the high-voltage winding.

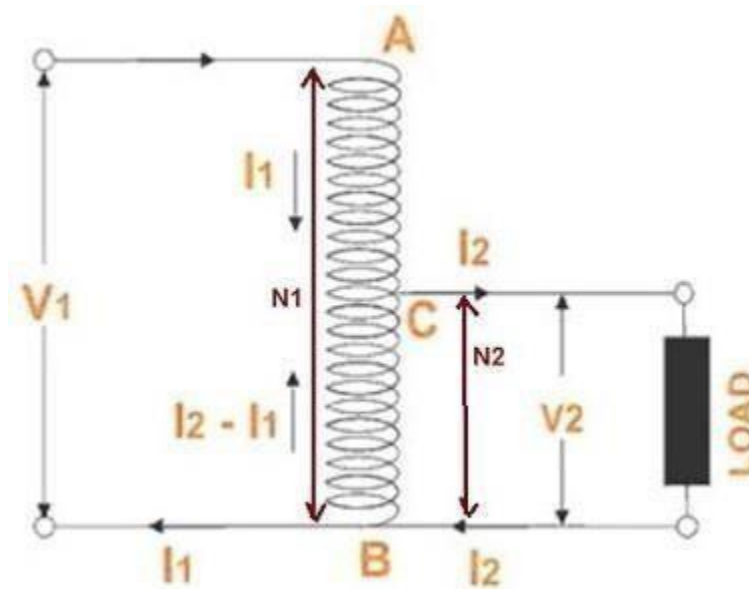

A simplified diagram of a Step-down Auto Transformer is shown in figure below.

Fig: Auto transformer

As shown in the figure above,  $N_1$  and  $N_2$  are the number of turns between winding AB and AC respectively. If a voltage  $V_1$  is applied across AB, an exciting current will start flowing through the full winding. Therefore, voltage per turn in winding AB is  $V_1/N_1$  and hence voltage across CB is  $(V_1/N_1)N_2$ .

As the load current is  $I_2$  and the current taken from the source is  $I_1$ , neglecting

losses Input Power = Output Power

$$V_1 I_1 \cos \theta_1 = V_2 I_2 \cos \theta_2 \quad (1)$$

Assuming internal impedance drop and losses to be negligible, power factor for primary and secondary will be almost same.

$$\cos \theta_1 = \cos \theta_2$$

Therefore from equation

$$(1), V_1 I_1 = V_2 I_2$$

So,

$$V_2 / V_1 = I_1 / I_2 = N_2 / N_1 = k(\text{say})$$

In our case of Step down Auto Transformer,  $k < 1$

Again, since the direction of flow of load current is in the opposite to the current flowing in the Primary

because of Lenz's Law, hence the current flowing in winding BC =  $(I_2 - I_1)$

$$I_{CB} = (I_2 - I_1)$$

Now the primary MMF =  $I_{AC} (N_1 - N_2)$

$$= I_1 (N_1 - N_2)$$

$$= N_1 I_1 - N_2 I_1$$

But  $N_1 / N_2 = I_2 / I_1$

So,  $N_1 I_1 = N_2 I_2$

Therefore,

Now the primary MMF =  $N_2 I_2 - N_2 I_1$

$$= (I_2 - I_1) N_2$$

$$= I_{CB} N_2 = \text{Secondary MMF}$$

Thus we see that in Auto Transformer, Transformer action take place between winding AC and BC. Thus VA of winding AC will be transferred to winding BC by Transformer action.

Therefore,

Transformed VA =  $V_{AB} I_{AB}$

$$= (V_1 - V_2) I_1 \quad (2)$$

Now, total VA input =  $V_1 I_1$

Therefore,

Transformed VA / Input VA =  $[(V_1 - V_2) I_1] / V_1 I_1$

$$= 1 - V_2 / V_1$$

$$= 1 - k$$

Thus we see that out of total input VA, only a part of it is transformed by Transformer action and remaining is therefore transferred by conduction.

So,

Conducted VA = Total Input – Transformed VA

$$= V_1 I_1 - (V_1 - V_2) I_1 \quad \text{From equation (1)}$$

$$= V_2 I_1$$

So,

Conducted VA / Input VA =  $V_2 I_1 / V_1 I_1$

$$= V_2 / V_1 = k$$

Thus in an Auto Transformer, a part of input power is delivered to the load by Transformer action while the remaining is by conduction method. Power transfer because of conduction method is possible in Auto Transformer because a part of winding is common to both the primary as well as secondary circuit.

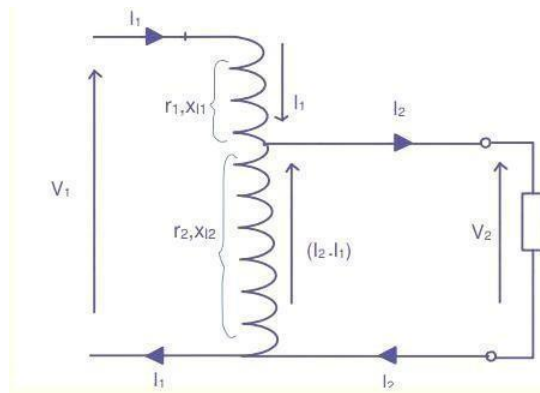

**EQUIVALENT CIRCUIT OF AUTOTRANSFORMER:**

Fig: Auto transformer on load

As mentioned earlier the magnetizing current can be neglected, for simplicity. Writing the Kirchoff's equation to the primary and secondary

we have

$$V_1 = E_1 + I_1(r_1 + jx_{l1}) - (I_2 - I_1)(r_2 + jx_{l2})$$

Note that the resistance  $r_1$  and leakage reactance  $x_{l1}$  refer to that part of the winding where only the primary current flows. Similarly on the load side

we have,

$$E_2 = V_2 + (I_2 - I_1)(r_2 + jx_{l2})$$

The voltage ratio  $V_1 : V_2 = E_1 : E_2 = T_1 : T_2 = a$  where  $T_1$  is the total turns of the primary. Then  $E_1 = aE_2$  and  $I_2 = aI_1$

The magnetization branch can now be hung across the mains for completeness. The above equivalent circuit can now be compared with the approximate equivalent circuit of a two winding case  $R_e = r_1 + a^2 r_2$  and  $X_e = x_{l1} + a^2 x_{l2}$ . Thus in the case of an auto transformer total value of the short circuit impedance is lower and so also the percentage resistance and reactance. Thus the full load regulation is lower. Having a smaller value of short circuit impedance is sometimes considered to be a disadvantage. That is because the short circuit currents become very large in those cases. The efficiency is higher in auto transformers compared to their two winding counter part at the same load. The phasor diagram of operation for the auto transformer drawing a load current at a lagging power factor angle of  $\theta_2$  is shown in Fig. 32. The magnetizing current is omitted here again for simplicity.

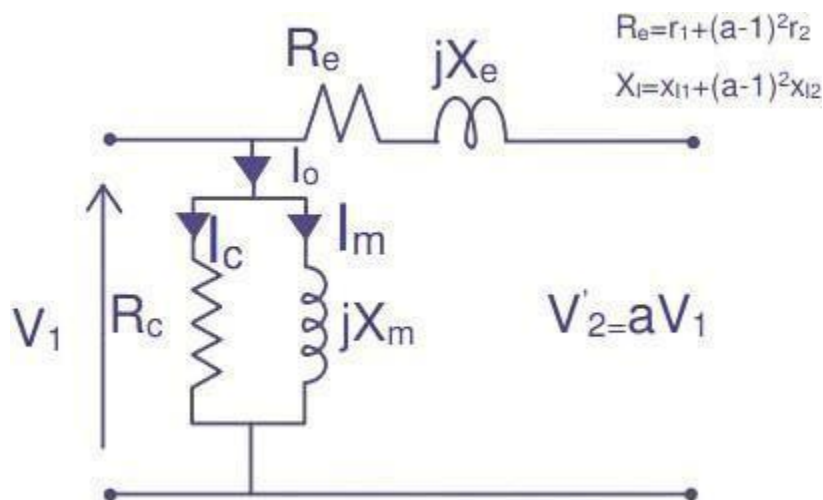

Fig: Equivalent Circuit

From the foregoing study it is seen that there are several advantages in going in for the autotransformer type of arrangement. The voltage/current transformation and impedance conversion aspects of a two winding transformer are retained but with lesser material (and hence lesser weight) used. The losses are reduced increasing the efficiency. Reactance is reduced resulting in better regulation characteristics. All





### **Applications of Auto transformer:**

- It is used as a starter to give upto 50 to 60% of full voltage to the stator of a squirrel cage induction motor during starting.
- It is used to give a small boost to a distribution cable, to correct the voltage drop.
- It is also used as a voltage regulator
- Used in power transmission and distribution system and also in the audio system and railways.

### **TAP-CHANGING TRANSFORMERS**

The change of voltage is affected by changing the numbers of turns of the transformer provided with taps. For sufficiently close control of voltage, taps are usually provided on the high voltage windings of the transformer. There are two types of tap-changing transformers

1. Off-load tap changing transformer
2. On-load tap changing transformer

### **Off-load tap-changing transformer:**

In this method, the transformer is disconnected from the main supply when the tap setting is to be changed. The tap setting is usually done manually. The off load tap changing transformer is shown in the figure below

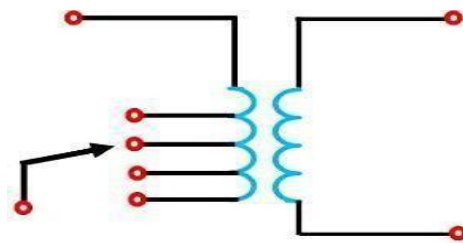

Off-load tap-changing transformer  
© 2012 M. S. S. S.

### **On-load tap-changing transformer:**

In order that the supply may not be interrupted, on-load tap changing transformer is used. Such a transformer is known as a tap-changing under load transformer. While tapping, two essential conditions are to be fulfilled.

- The load circuit should not be broken to avoid arcing and prevent the damage of contacts.

- No parts of the windings should be short-circuited while adjusting the tap.

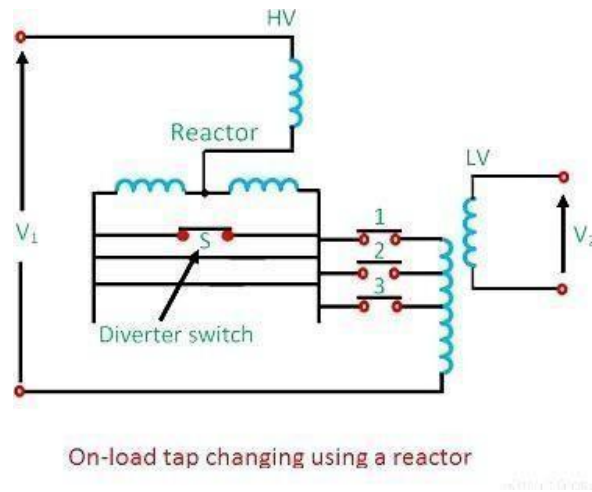

The tap changing employing a center tapped reactor R show in the figure above. Here S is the diverter switch, and 1, 2, 3 are selector switch. The transformer is in operation with switches 1 and S closed. To change to tap 2, switch S is opened, and 2 is closed. Switch 1 is then opened, and S closed to complete the tap change. It is to be noted that the diverter switch operates on load, and no current flows in the selector switches during tap changing. During the tap change only half of the reactance which limits the

It is to be noted that the diverter switch operates on load, and no current flows in the selector switches during tap changing. During the tap change, only half of the reactance which limits the current is connected in the circuit.

### **HARMONICS IN THREE PHASE TRANSFORMERS**

The harmonic is the distortion in the waveform of the voltage and current. It is the integral multiple of some reference waves. The harmonic wave increases the core and copper loss of the transformer and hence reduces their efficiency. It also increases the dielectric stress on the insulation of the transformer.

In a three-phase transformer, the non-sinusoidal nature of magnetising current produces sinusoidal flux which gives rise to the undesirable phenomenon. The phase magnetising currents in transformer should contain third harmonics and higher harmonics necessary to produce a sinusoidal flux.

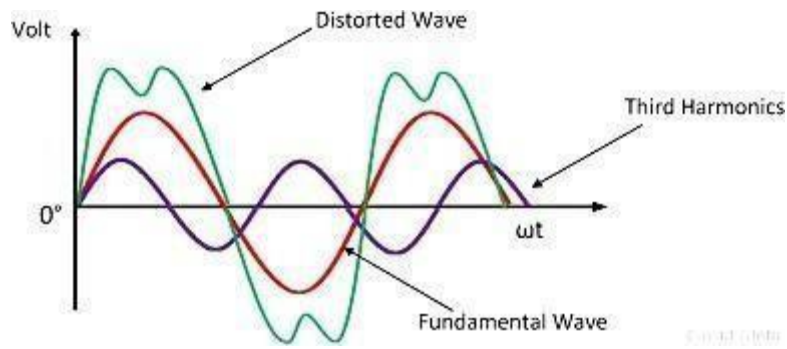

Fig: Harmonics in transformers

If the phase voltage across each phase is to remain sinusoidal, then the phase magnetising currents must

$$I_{AO} = I_{1m} \sin \omega t + I_{3m} \sin(3\omega t + \phi_3) + I_{5m} \sin(5\omega t + \phi_5) \dots \dots \text{equ(1)}$$

$$I_{BO} = I_{1m} \sin(\omega t - 120^\circ) + I_{3m} \sin[3(\omega t - 120^\circ) + \phi_3] + I_{5m} \sin[3(\omega t - 120^\circ) + \phi_5]$$

$$I_{CO} = I_{1m} \sin(\omega t + 120^\circ) + I_{3m} \sin(3\omega t + \phi_3) + I_{5m} \sin(5\omega t + 120^\circ + \phi_5) \dots \dots \text{equ(2)}$$

$$I_{AO} = I_{1m} \sin(\omega t - 240^\circ) + I_{3m} \sin[3(\omega t - 240^\circ) + \phi_3] + I_{5m} \sin[3(\omega t - 240^\circ) + \phi_5]$$

$$I_{CO} = I_{1m} \sin(\omega t - 240^\circ) + I_{3m} \sin(3\omega t + \phi_3) + I_{5m} \sin(5\omega t + 240^\circ + \phi_5) \dots \dots \dots \text{equ(3)}$$

be of the following form.

It is seen from equation (1), (2), and (3) that the third harmonics in the three currents are co-phase, that is they have the same phase. The fifth harmonics have different phases.

### Delta Connection

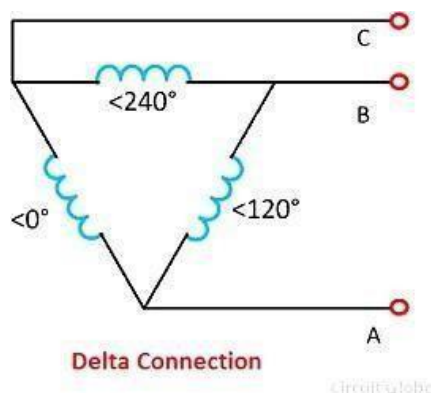

Let the  $I_{AO}$ ,  $I_{BO}$  and the  $I_{CO}$  represent the phase magnetising current in a delta connection. The line currents can be found by subtracting two phases current. For examples,

$$I_{ABO} = I_{AO} - I_{BO}$$

$I_{ABO} = \sqrt{3}I_{1m}\sin(\omega t + 30^\circ) - \sqrt{3}I_{5m}\sin(5\omega t - 30^\circ + \phi_5) + \dots$  equ(4) The third harmonic present in the phase magnetising current of three phase transformer is not present in the line current. The

third harmonic components are co-phase and hence cancel out in the line. The third harmonic components are flows round the closed loop of the delta.

The delta connection only allows a sinusoidal flux and voltage with no third harmonic current in the transmission line. For this reason majority of the 3-phase transformer has delta connected windings and in places where it is not convenient to have an either primary or secondary connected in delta, a tertiary winding is provided. The tertiary windings carry the circulating third harmonics current required by the sinusoidal flux in each limb of the core.

In a delta connection, the voltage acting around the closed delta is,

$$V_A + V_B + V_C = 3V_{3m}\sin(3\omega t + \phi_3') \dots \dots equ(11)$$

This is a third harmonic voltage and it will circulate a third harmonic current round the closed loop of the delta

## Star connection

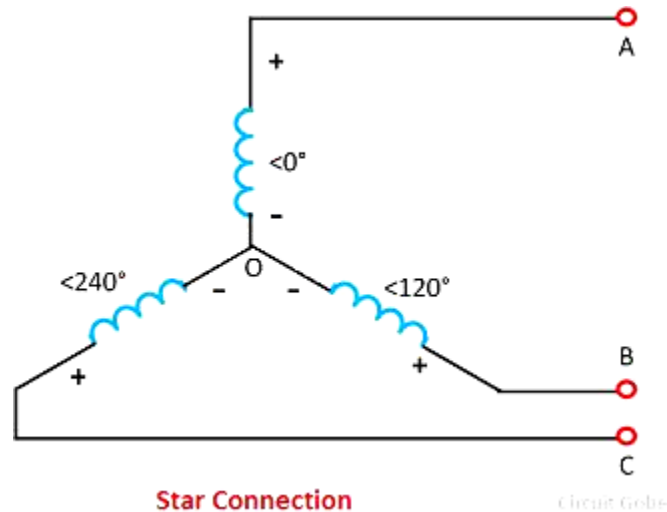

If  $I_{AO}$ ,  $I_{BO}$  and  $I_{CO}$ , represents the phase magnetising current in a star connection,

$$I_{AO} + I_{BO} + I_{CO} = I_N \dots \dots \text{equ}(5)$$

$$I_{AO} + I_{BO} + I_{CO} = 3I_{3m} \sin(3\omega t + \phi_3) \dots \dots \text{equ}(6)$$

Where  $I_n$  is the current in the neutral wire.

The harmonics above the seventh be neglected. The equation (6) shows that under the balanced condition the current flow in the neutral wire is the third harmonic current. The magnitude of the third harmonics current is thrice the magnitude of each third phase current. The thirds harmonic current produced inductive interference with communication circuit. If the supply to the star connection is three wires,

$$3I_{3m} \sin(3\omega t + \phi_3) = 0$$

$$I_{3m} = 0$$

neutral current must be zero and therefore

Thus, it is seen that the three wire star connection suppresses the flow of harmonic and magnetising currents. For a four wire star-connected system, the in phase third harmonic current flow in the neutral wire.

Similarly, the third balance phase voltage containing harmonics can be written as

$$V_A = V_{1m} \sin(\omega t + \phi_1') + V_{3m} \sin(3\omega t + \phi_3') + V_{5m} \sin(5\omega t + \phi_5') \dots \dots \text{equ}(7)$$

$$V_B = V_{1m} \sin(\omega t - 120^\circ + \phi_1') + V_{3m} \sin(3\omega t + \phi_3') \\ + V_{5m} \sin(5\omega t + 120^\circ + \phi_5') \dots \dots \text{equ}(8)$$

$$V_C = V_{1m} \sin(\omega t - 240^\circ + \phi_1') + V_{3m} \sin(3\omega t + \phi_3') \\ + V_{5m} \sin(5(\omega t + 240^\circ + \phi_5')) \dots \dots \dots \text{equ}(9)$$

The equation (7), (8) and (9) shows that the third harmonics in the three phase voltage have the same phase. The line voltage in a star connection can be obtained by subtracting two phase voltages. For example

$$V_{AB} = V_A - V_B$$

$$V_{AB} = \sqrt{3}V_{1m} \sin(\omega t + 30^\circ + \phi_1') - \sqrt{3}V_{5m} \sin(5\omega t + 30^\circ + \phi_5') + \dots \text{equ}(10)$$

From equation (10) it is seen that the third harmonics is not present in the line to line voltage of a star connection. This applies to all triplers harmonics.

**IDEAL INSTITUTE OF TECHNOLOGY**

**Mid-Term-I 2023**

**Branch: Electrical Engineering**

**Subject: FEMM**

**SEM: III**

**Marks: 20**

---

**Note:** Question no.1 is compulsory.

Attempt either question 2 or 3.

**Q.1) Attempt the following (10M)**

a) Write the differences between an electric circuit and magnetic circuit.

b) Explain the different types of losses in the electromagnetic circuits.

Explain the precautions to reduce the hysteresis loss and eddy current loss.

**Q.2) Attempt the following (10M)**

a) Derive the energy balance equation and co-energy.

b) Explain the concept of singly excited machines and the expression for the electromagnetic torque.

**Q.3) Attempt the following. (10M)**

a) Derive the expression for electromagnetic torque for doubly excited system in terms of angular rate of change of self and mutual inductance of stator and rotor winding.

**IDEAL INSTITUTE OF TECHNOLOGY**

**Mid-Term-I 2023**

**Branch: Electrical Engineering**

**Subject: FEMM**

**SEM: VII**

**Marks: 20**

---

**Note:** Question no.1 is compulsory.

Attempt either question 2 or 3.

**Q.1) Attempt the following (10M)**

a) Write the differences between an electric circuit and magnetic circuit.

b) Explain the different types of losses in the electromagnetic circuits.

Explain the precautions to reduce the hysteresis loss and eddy current loss.

**Q.2) Attempt the following (10M)**

b) Derive the energy balance equation and co-energy.

b) Explain the concept of singly excited machines and the expression for the electromagnetic torque.

**Q.3) Attempt the following. (10M)**

a) Derive the expression for electromagnetic torque for doubly excited system in terms of angular rate of change of self and mutual inductance of stator and rotor winding.



**IDEAL INSTITUTE OF TECHNOLOGY**

**Mid-Term- II (2023-24)**

**Branch: Electrical Engineering**

**Subject: FEMM**

**SEM: III**

**Marks: 20**

---

**Note:** Question no.1 is compulsory.

Attempt either question 2 or 3

**Q.1) Attempt the following (10M)**

- a) Give classification of transducers.
- b) Explain the construction and working of digital tachometer.

**Q.2) Attempt the following (10M)**

- a) What are transducers explain LVDT and thermocouples with diagram.
- b) Explain the working principle, construction of moving coil instruments and hence derive the torque equation.

**Q.3) Discuss in brief: (10M)**

- a) Explain the working of ramp type digital voltmeter (DVM) with the help of block diagram and waveforms.

**IDEAL INSTITUTE OF TECHNOLOGY**

**Mid-Term- II (2023-24)**

**Branch: Electrical Engineering**

**Subject: FEMM**

**SEM: III**

**Marks: 20**

---

**Note:** Question no.1 is compulsory.

Attempt either question 2 or 3

**Q.1) Attempt the following (10M)**

- a) Give classification of transducers.
- b) Explain the construction and working of digital tachometer.

**Q.2) Attempt the following (10M)**

- a) What are transducers explain LVDT and thermocouples with diagram.
- b) Explain the working principle, construction of moving coil instruments and hence derive the torque equation.

**Q.3) Discuss in brief: (10M)**

- a) Explain the working of ramp type digital voltmeter (DVM) with the help of block diagram and waveforms.